



**Schäfer + Peters GmbH**  
Competence in Stainless Steel



2026



**OUR CERTIFICATIONS**

*FOR YOUR SAFETY*



**Schäfer + Peters GmbH**

Zeilbaumweg 32  
DE-74613 Öhringen

Tel. +49 (0) 7941 6094-0  
Fax +49 (0) 7941 6094-700

[info@schaefer-peters.com](mailto:info@schaefer-peters.com)  
[www.schaefer-peters.com](http://www.schaefer-peters.com)

*We cannot assume liability for the texts, information or translations provided being up-to-date, correct or complete.*

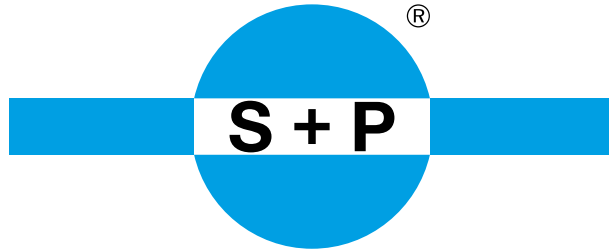

## Welcome to Schäfer + Peters

Schäfer + Peters is your partner for stainless steel and anti-corrosion fasteners, DIN and standard parts such as wood screws, metric screws, tapping screws, washers, nuts and also products such as heavy-duty fastenings, safety screws and solar fastenings as well as special and drawing parts. All items are available in various versions.

We bond well with our customers. This relationship is backed up by us holding in excess of 37 000 different items in our warehouse, employing 270 enthusiastic and qualified members of staff and deploying modern quality management.



[www.schaefer-peters.com](http://www.schaefer-peters.com)

## Our approvals give you peace of mind

---

To ensure the correct use and implementation of a general building-authority approval and correct use of the mark of conformity together with a fully functioning quality management system, we have provided explanations of

the individual elements for you. The products listed below satisfy all these requirements.

## Explanation of building-authority approval

---

### Approvals for construction products and types of construction

The Deutsches Institut für Bautechnik (DIBt) is the German licensing office responsible for issuing general building-authority approvals (abZ) for construction products and types of construction and European technical approvals (ETA) for construction products and assemblies.

Around 2000 national approvals are issued annually. At European level, the DIBt competes with other European licensing offices and is a leader in issuing European technical approvals. The institute works on behalf of companies selling their products in Germany, Europe and the rest of the world.

General building-authority approvals are issued within the scope of application of state building codes for those construction products and types of construction for which there is no generally-accepted, good engineering practice, in particular if the products or types of construction have no DIN standards, or if they deviate significantly from these. They are reliable proof of usability for construction products and types of construction in terms of structural engineering requirements of buildings.

European technical approvals are issued for construction products within the scope of application of the German Construction Products Act; they reliably document the usability of a construction product.

### What is a general building-authority approval?

A general building-authority approval is evidence of the usability of a non-regulated construction product or type of construction in accordance with the state building codes (Section 18 para.1 and Section 21 para. 1 of the German Model Building Regulations [MBO]).

Building works should be arranged, set up, modified and maintained such that public health and safety is not put at risk, especially risks of death, harm to health and livelihood (Section 3 para.1 MBO).

## Explanation of mark of conformity

### What is the mark of conformity and when can or must I use it for labelling?

Once approval has been granted, the construction products still need confirmation that they comply with the general building-authority approval. Depending on the clauses in the approval, this takes the form of a declaration of compliance from the manufacturer or a compliance certificate issued by a certification body.

In the latter case, external monitoring must also be established and undertaken by a monitoring body. External monitoring regularly checks whether the construction product corresponds to the general building-authority approval.

The manufacturer must show that a declaration of compliance or a certificate of compliance has been issued by labelling the construction products with the mark of conformity and stating the purpose of use. The product may only be used as stated in the approval once the mark of conformity is in place.

In accordance with Section 24, para. 4 of the MBO, the mark of conformity consists of the German letter “Ü” and the following details

1. Name of manufacturer; plus manufacturing plant if the manufacturer's name does not allow the construction product to be clearly assigned to a manufacturing plant; instead of the manufacturer's name, the name of the construction product's distributor may be stated along with details of the manufacturing plant; details of the manufacturing plant may be encoded if the plant can be clearly established at any time from the manufacturer and distributor and, if a certificate of conformity is required, from the certification body and monitoring body.



2. The name of the general building-authority approval as “Z” and its number

3. The name or symbol of the certification body if the involvement of a certification body is prescribed.

The details stated in para. 1 should be provided in the area within the letter “Ü” or immediately adjacent to it.

## European technical approval (ETA)

---

### What is a European technical approval (ETA)?

The European technical approval is evidence of the usability of a construction product as laid down in the Construction Products Directive, implemented in Germany through the Construction Products Law.

The ETA is based on tests, analyses and a technical assessment by bodies that have been appointed for this purpose by the EU member states. It covers all product features which may be significant to meeting statutory requirements in the member states. The level of performance required may differ between countries and depending on intended use. European technical approval can be issued for construction products for which there are (as yet) no harmonised standards according to the Construction Products Directive or which deviate greatly from a harmonised standard.

The assessment of usability is based either on approval

guidelines (European Technical Approval Guidelines - ETAGs), which were written by the EOTA for the relevant product areas, or assessment criteria agreed on with other EOTA bodies especially for an application for approval. In the interests of manufacturers, evidence already provided to the DIBt in the national approval process is also used for the European process as far as possible.

The European technical approval allows the manufacturer to use the CE mark on the construction product and therefore provides access to the European market. By using the CE mark, the manufacturer confirms that it has undertaken the process prescribed to demonstrate that the product complies with the approval.

## CE mark

---

### General information about the CE mark

The CE mark was created to ensure the free movement of goods within the EU with safe products. A product may only be marketed and operated once it has gone through a conformity assessment process in accordance with the applicable EC Directives. CE marking is based on the ZA appendix of a harmonised European standard (hEN) or a European technical approval (ETA).

### What products require a CE mark?

Manufacturers of products which fall under one of the 23 EC Directives requiring mandatory CE marking must provide their products with the CE mark. The EU does not require CE marking for some product groups. The requirements can be found in the relevant EC Directive for the product. All EC Directives are listed in the Appendix.

### Who is responsible for CE marking?

The manufacturer of the product is responsible for this marking. Should a manufacturer from outside the EU fail to label the product, this obligation passes to its agent in the EU or the importer or ultimately the party marketing or selling the product.

### Where must the CE mark be placed?

The CE mark should be permanently placed somewhere where it is clearly visible and legible on the product or, if there isn't enough space, on a sticker stuck on it. If the type of product does not permit this, it is placed on the packaging (if used) and accompanying documents, if the relevant Directive stipulates such documents.

### Do all ISO 4014 compliant screws have CE marking?

No. For example, if screw connections not prestressed as designed are needed for metal construction in accordance with DIN EN 15048-1, this should be stated when ordering. These items are then tested according to the requirements of the standard and if the test is passed are delivered with the corresponding certificates.

### Is the CE mark a quality seal?

The CE mark is not a quality symbol or seal. The manufacturer simply uses the mark to assure customers that the product complies with the safety requirements of the relevant CE guidelines. The process does not, however, involve independent testing on behalf of an EU authority to establish whether the product is free from dangerous substances or meets the current safety requirements.

## Key terms

---

### Construction products

Construction products are

1. construction materials, components and systems manufactured to be permanently installed in structures above or below ground,
2. systems pre-assembled out of construction materials and components to be joined with the soil, such as prefabricated houses, prefabricated garages, silos, etc.

### Construction Products Law (BauPG)

The Construction Products Law (BauPG) is the implementation of the European Construction Products Directive into national law by the Federal Republic of Germany. It governs the marketing, the free movement of goods and the use of construction products and defines the construction product's usability depending on how it is used in a structure.

### Construction Products Directive 89/106/EEC (CPD)

The aim of the CPD is to define essential requirements (ER) of the structure in which construction products are used. These requirements must be met over an appropriate period of time according to the Appendix of the CPD with normal maintenance. These requirements include:

- mechanical strength and stability
- fire protection
- hygiene, health and environmental protection
- safety in use
- sound insulation
- energy saving and thermal protection

Fulfilment of these requirements is the basis for CE marking, with which the manufacturer demonstrates that the product satisfies all the essential requirements of the Directive and that the relevant EU Directives are observed.

### Construction Products Regulation 305/2011EU (CPR)

The Construction Products Regulation (305/2011/EU – CPR) stipulates harmonised conditions for the marketing of construction products. It came into force on 24 April 2011 and supersedes the Construction Products Directive (89/106/EEC - CPD). The transition period ended on 1 July 2013.

### Building Regulation List

The Building Regulation Lists published once a year by the Deutsches Institut für Bautechnik (DIBt) provide an up-to-date and comprehensive indication of the building-authority requirements relating to the use of construction products. The lists include construction products and types of construction for which building-authority requirements exist. The Building Regulation List has three sections covering different domains:

- List A: Construction products and types of construction according to state building codes
- List B: Construction products according to EU Directives with CE marking
- List C: Construction products of minor importance to building authorities

### Harmonised European standards (hEN)

Standards for which the European Commission has issued a mandate. These standards must satisfy the safety levels defined by the member states in the mandate. Once published in the EU's Official Journal and after the coexistence period, these standards are binding for all member states.

### Declaration of conformity

Through the declaration of conformity, the manufacturer confirms that the specified conformity assessment procedures have been undertaken and that the product corresponds to the applicable Directives. The declaration of conformity forms the basis for use of the CE mark as prescribed by law.



## S+P quality management

Our DIN EN ISO 9001:2015 quality management system guarantees our implementation of the necessary quality objectives. This includes traditional quality assurance

as well as the planning and execution of operational procedures throughout the company.

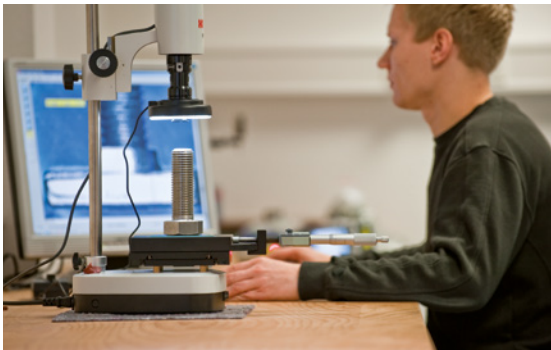

**Hitec  
measuring microscope**

→ This test device allows distances, angles, areas, circles, radii and diameters to be measured with great accuracy. The measurements can be documented in a digital format at any time.



**Schatz  
torque testing device**

→ The Schatz torque analysis device allows ultimate torques, screw-in torques or even rotary angles to be checked.



**Urban  
screw unit**

→ This screw unit can be used to measure screw-in times under the influence of different weights. It is particularly useful for self-drilling screws and timber construction screws. Perfect fastener analyses are possible when combined with the Schatz transmitter.



**X-ray  
analysis device**

→ The optimum way of analysing the material components of the stainless steel fasteners and establishing their composition, regardless of whether they contain chrome, nickel or molybdenum.

### Quality assurance

Many of our products are already checked by a neutral test institute and regularly inspected according to the requirements of external monitoring. For various products this has been confirmed by way of a building-authority approval from the DIBt.

In our quality assurance, using a multitude of measurement and test devices we can perform tests of, for example, dimensional uniformity, torques, screw-in times, strength and even material analyses in our own test laboratory.

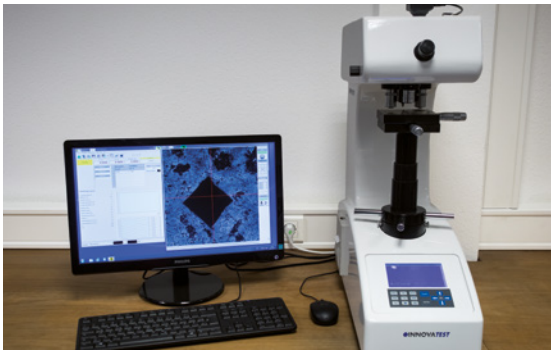

**Nexus  
premium hardness testing device**

→ This hardness testing device can be used for high-precision hardness testing according to Vickers (and Knopp / Brinell). Its measurement range is 0.2 to 30 kp.



**Dark chamber with integrated UV light  
sources and white light**

→ It can be used to provide optical evidence of the smooth coating applied on the fastening elements.

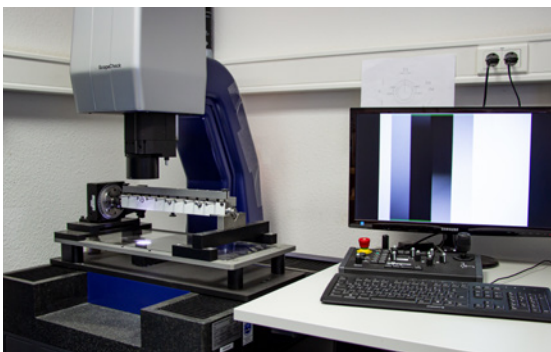

**Werth  
ScopeCheck S**

→ The 3D-CNC multi-sensor coordinate measuring machine measures our connecting elements and prints the corresponding test report within minutes.

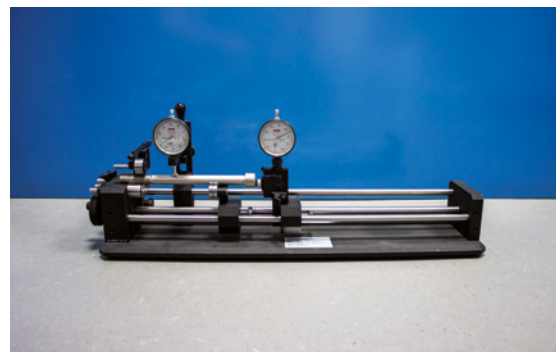

**Concentricity  
test device**

→ This test device can be used to determine screw straightness, the concentricity of the head to the screw axis, the concentricity of the drive to the head diameter and/or to the screw axis up to a screw length of 500 mm.

# PRODUCT ALLOCATION FOR AUTHORISATION

	ETA-11/0283	ETA-12/0086	ETA-13/0178	ETA-11/0196	ETA-23/1031	ETA-24/0427	ETA-15/0514	ETA-21/0425	Z-14.4-602	Z-14.4-706	Z-30.3-6	EN 14592 CE	UKTA-22/6473	
603 - Ø 6 bis Ø 24											x			
4762 - Ø 6 bis Ø 24											x			
931 - Ø 6 bis Ø 24											x			
933 - Ø 6 bis Ø 24											x			
934 - Ø 6 bis Ø 24											x			
976 - Ø 6 bis Ø 24											x			
4014 - Ø 6 bis Ø 24											x			
4017 - Ø 6 bis Ø 24											x			
4032 - Ø 6 bis Ø 24											x			
7380 -1 - Ø 6 bis Ø 24											x			
7380 -2 - Ø 6 bis Ø 24											x			
10642 - Ø 6 bis Ø 24											x			
9001 - Ø 7,5/10/12							x	x						
9004 - Ø 8/10/12/16				x										
9032 - Typ 1									x					
9040 - Ø 4,0/4,5/5,0/6,0	x													x
9041 - Ø 3,2												x		
9042 - Ø 4,0/4,5/5,0												x		
9043 - A2 + A4												x		
9043 - 1.4006	x													x
9044 - Ø 4,0/4,5/5,0/6,0	x													x
9045 - Ø 3,0/3,5/4,0/4,5/5,0/6,0	x													x
9046 - Ø 3,0/3,5/4,0/4,5/5,0/6,0	x													x
9047 - Ø 3,0/3,5/4,0/4,5/5,0/6,0/8,0/10	x													x
9147 - Ø 3,0/3,5/4,0/4,5/5,0/6,0/8,0/10	x													x
9048 - Ø 3,0/3,5/4,0/4,5/5,0/6,0	x													x
9049 - Ø 3,0/3,5/4,0/4,5/5,0/6,0	x													x
9050 - Ø 3,0/3,5/4,0/4,5/5,0/6,0	x													x
9250 - Ø 5,0/6,0/8,0	x													x
9057 - Ø 6,3/6,5 bis L 64		x												
9057 - Ø 6,3/6,5 ab L 75		x	x											
9059 - Ø 6,3/6,5 bis L 64		x												
9059 - Ø 6,3/6,5 ab L 75		x	x											
9098 - Ø 6,3/6,5/8,0 bis L 64		x												
9098 - Ø 6,3/6,5/8,0 ab L 75		x	x											
9142 - Ø 4,2/4,8												x		
9143 - Ø 5,3												x		
9086 - Ø 4,8/5,5												x		
9082 - Ø 6/8/10/12									x					
9182 A - Ø 8,4						x								
9182 BZ - Ø 8,0/10,0						x								
9241 - Ø 3,2/4,0/4,5/5,0	x													x
9242 - Ø 3,2/4,0/4,5/5,0	x													x
9243 - Ø 5,5	x													x
9244 - Ø 3,5/4,0/4,5/5,0/6,0	x													x
9245 - Ø 4,0/4,5/5,0	x													x
9246 - Ø 3,5/4,0/4,5/5,0/6,0	x													x
9504 - SP-B2-2-4,8		x												
9504 - SP-B2-2-6,3		x												
9504 - SP-B2-2-6,0		x												
9504 - SP-B2-3-5,5		x												
9504 - SP-B2-6-5,5 bis L60		x												
9504 - SP-B2-6-5,5 ab L70		x	x											
9504 - SP-B2-12-5,5 bis L 60		x												
9504 - SP-B2-12-5,5 ab L 70		x	x											
9504 - SP-B2-2H-5,5		x												
9504 - SP-B2-6-6,3 bis L 60		x												
9504 - SP-B2-6-6,3 ab L 70		x	x											
9505 - Ø 4,5/6,0					x									
9506 - Ø 4,5/6,0					x									
9604 - SP-A2-6-5,5		x												

UKTA-22/6473

CE - mark

Building authority approval / Monitored

European Technical Approval

# Certificate

Standard **ISO 14001:2015**  
Certificate Registr. No. **01 104 2300919**

Certificate Holder:



**Schäfer + Peters GmbH**  
Zeilbaumweg 32  
74613 Öhringen  
Germany

Scope: Distribution of Stainless Steel fixing elements

Proof has been furnished by means of an audit that the requirements of ISO 14001:2015 are met.

Validity: The certificate is valid from 2025-02-07 until 2028-02-06.  
First certification 2025

2025-02-13

TÜV Rheinland Cert GmbH  
Am Grauen Stein · 51105 Köln

www.tuv.com



# Certificate

Standard **ISO 50001:2018**  
Certificate Registr. No. **01 407 2300919**

Certificate Holder:



**Schäfer + Peters GmbH**  
Zeilbaumweg 32  
74613 Öhringen  
Germany

Scope: Distribution of Stainless Steel fixing elements

Proof has been furnished by means of an audit that the requirements of ISO 50001:2018 are met.

Validity: The certificate is valid from 2024-03-11 until 2027-03-10.  
First certification 2024

2024-08-01

TÜV Rheinland Cert GmbH  
Am Grauen Stein · 51105 Köln

www.tuv.com



© TÜV, TÜV and TÜV are registered trademarks. Utilization and application requires prior approval.

© TÜV, TÜV and TÜV are registered trademarks. Utilization and application requires prior approval.



## CERTIFICATE



This is to certify that



**Schäfer + Peters GmbH**

Zeilbaumweg 32  
74613 Öhringen  
Germany

has implemented and maintains a **Quality Management System**.

Scope:  
Distribution of Stainless Steel fixing elements

Through an audit, documented in a report, it was verified that the management system fulfills the requirements of the following standard:

**ISO 9001 : 2015**

Certificate registration no. 019819 QM15  
Valid from 2023-12-15  
Valid until 2026-12-14  
Date of certification 2023-12-08



**DQS GmbH**

Christian Gerling  
Managing Director

Accredited Body: DQS GmbH, August-Schanz-Straße 21, 60433 Frankfurt am Main, Germany  
The validity of this certificate can only be verified by the QR code.



Competence in  
Stainless Steel

# SP-HBS TIMBER SCREWS TX

Ideal for screwing in wood.

The optimal thread geometry ensures the best grip in a variety of wood materials. By recording TX optimum power transmission is achieved.

TX:

Art.-Nr. 9045

Art.-Nr. 9046

Art.-Nr. 9047

Material: A2/A4



## SP-HBS TIMBER SCREW ART.-NR. 9047 PARTIAL THREAD

Countersunk head with TX drive

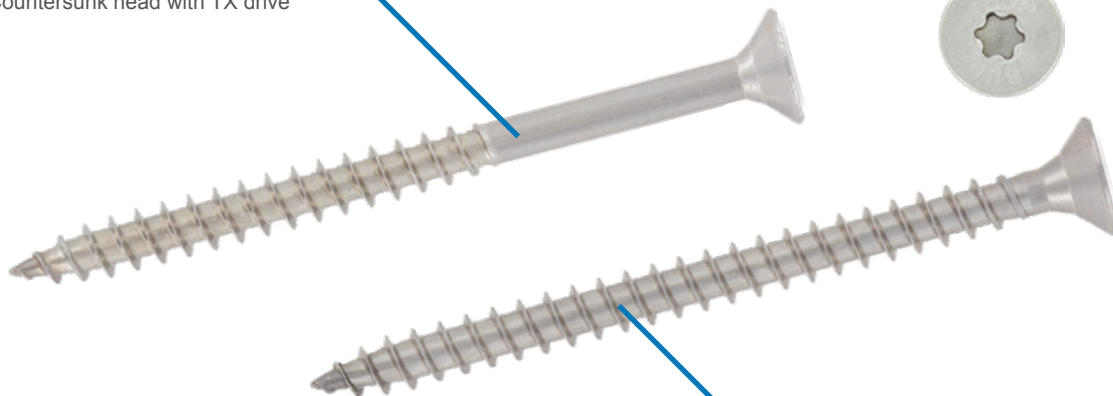

TX DRIVE

## SP-HBS TIMBER SCREW ART.-NR. 9047 FULLTHREAD

Countersunk head with fullthread

## SP-HBS TIMBER SCREW ART.-NR. 9045 FULL- OR PARTIAL THREAD

Pan head with TX-drive



## SP-HBS TIMBER SCREW ART.-NR. 9046 FULL- OR PARTIAL THREAD

Raised countersunk head with TX-drive



# SP-HBS TIMBER SCREWS PZ

Ideal for screwing in wood.  
The optimal thread geometry ensures the best grip in a variety of wood materials.

PZ:

Art.-Nr. 9048

Art.-Nr. 9049

Art.-Nr. 9050

Material: A2/A4



## SP-HBS TIMBER SCREW ART.-NR. 9050 PARTIAL THREAD

Countersunk head with pozidrive

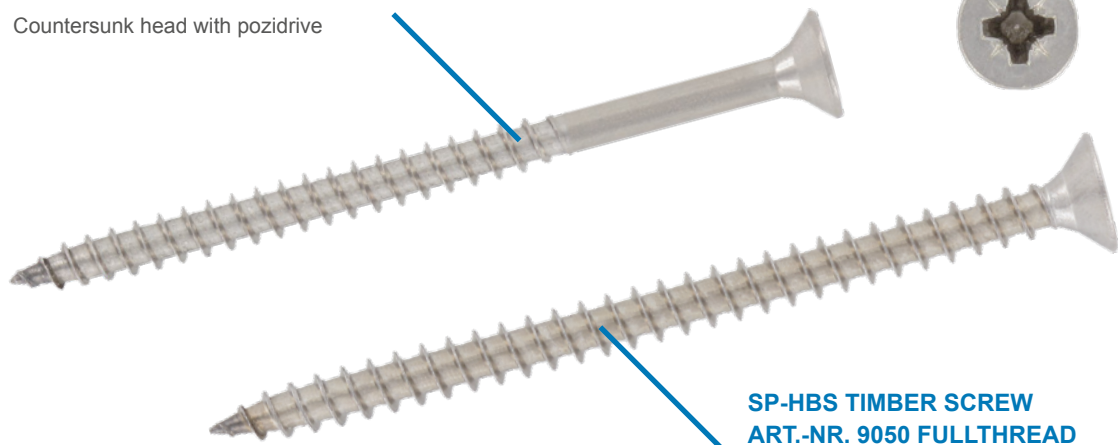

POZIDRIVE

## SP-HBS TIMBER SCREW ART.-NR. 9050 FULLTHREAD

Countersunk head with pozidrive

## SP-HBS TIMBER SCREW ART.-NR. 9048 FULL- OR PARTIAL THREAD

Pan head with Pozidrive



## SP-HBS HOLZBAUSCHRAUBE ART.-NR. 9049 FULL- OR PARTIAL THREAD

Raised countersunk head with Pozidrive



# HBS TIMBER SCREWS WITH CUTTING POINT

also in  
Martensitic  
class C1 stainless steel  
**1.4006**

Double CSK head timber screws with ribs, cutting point.

Ideal for screwing in wood. The optimal thread geometry ensures the best grip in a variety of wood materials. By recording TX optimum power transmission is achieved.

Art.-Nr. 9147

Material: A2/A4/1.4006



## FEATURES:

- countersunk 90°
- double countersunk head
- TX drive
- cutting point
- ribs under the head

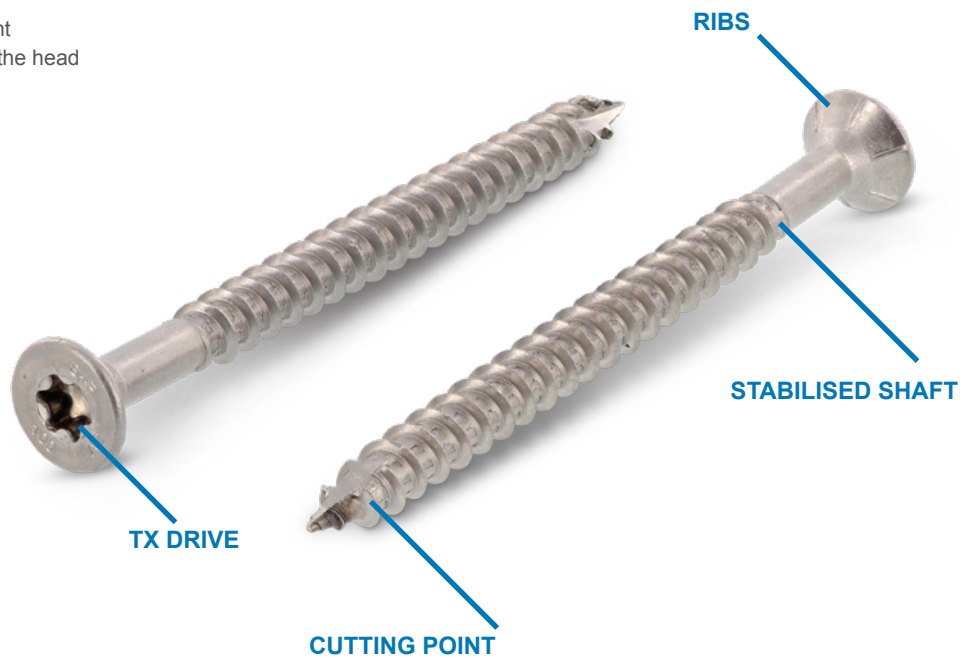

## PRODUCT BENEFITS:

### Wobble-free drive

The TX internal, multi-tooth drive allows easy and secure screw driving from setting to countersinking.

### No predrilling

Predrilling is not needed, even in most hardwoods. But given the many different properties of hardwoods we would always recommend testing before application.

# HBS PAN WASHER HEAD TIMBER SCREWS WITH CUTTING POINT

Ideal for outdoor screw connections such as solar equipment, car ports, balconies, steps, playground equipment, prefabricated houses and all supporting components.

A secure and visually appealing screw connection – the wood construction screw with reinforced pan head, cutting notch and TX hexagon socket drive.

Art.-Nr. 9250  
Material: A2/A4



## FEATURES:

- Pan washer head timber screws
- cutting point
- Anti-Friction-coating
- TX drive
- fullthread

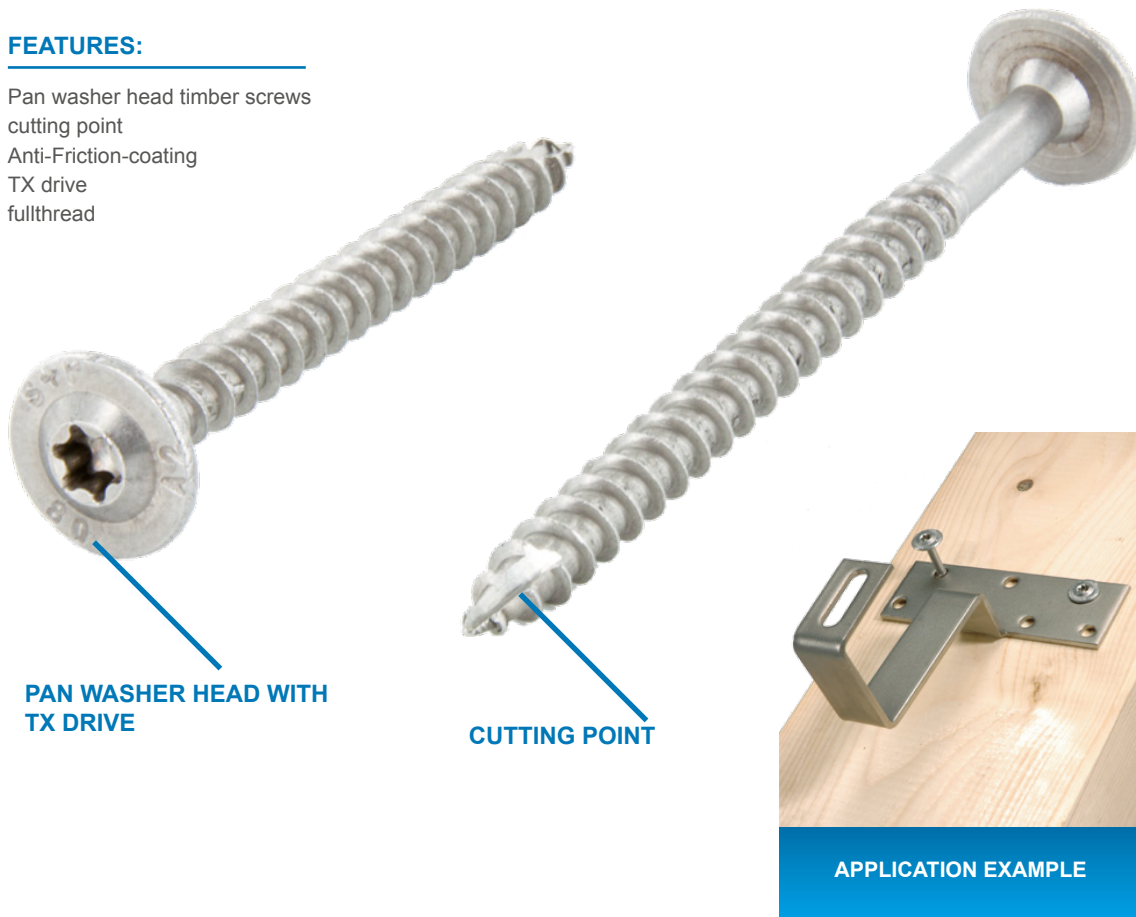

PAN WASHER HEAD WITH TX DRIVE

CUTTING POINT

APPLICATION EXAMPLE

## PRODUCT BENEFITS:

### Great hold

Up to 50% fewer screws are needed as the head pull-through values are considerably greater than those of a countersunk screw.

### No splintering of the wood

The cutting notch in the threaded end relieves tension from the wood, thereby preventing cracking.

### Easy to attach

Ensures a rapid thread grip.

### Special sliding coating

Guarantees low screw-in torques and therefore little effort required.

### Anti-Friction-coating

Guarantees low screw-in torques and less force is therefore needed.

### Wobble-free driving feature

The TX driving feature allows the screw to be easily and securely screwed in when the screw is attached and countersunk. Small dimensions ideal when using metal parts like column bases or roof hooks on timber structures.

# SP-SUPER DRILL

Super-Drill CSK head timber screws with drilling point

Ideal for outdoor screw connections such as those in boarding, fences, balconies, steps, playground equipment, facades and terraces.

Can also be drilled through thin-walled soft metal sheets, e.g. aluminium up to a thickness of 2 mm.

Art.-Nr. 9040

Material: A2



## FEATURES:

### SUPER-DRILL

- Reinforced head
- Stabilised shaft
- Distinct thread
- Anti-Friction-coating
- ribs under the head
- TX drive

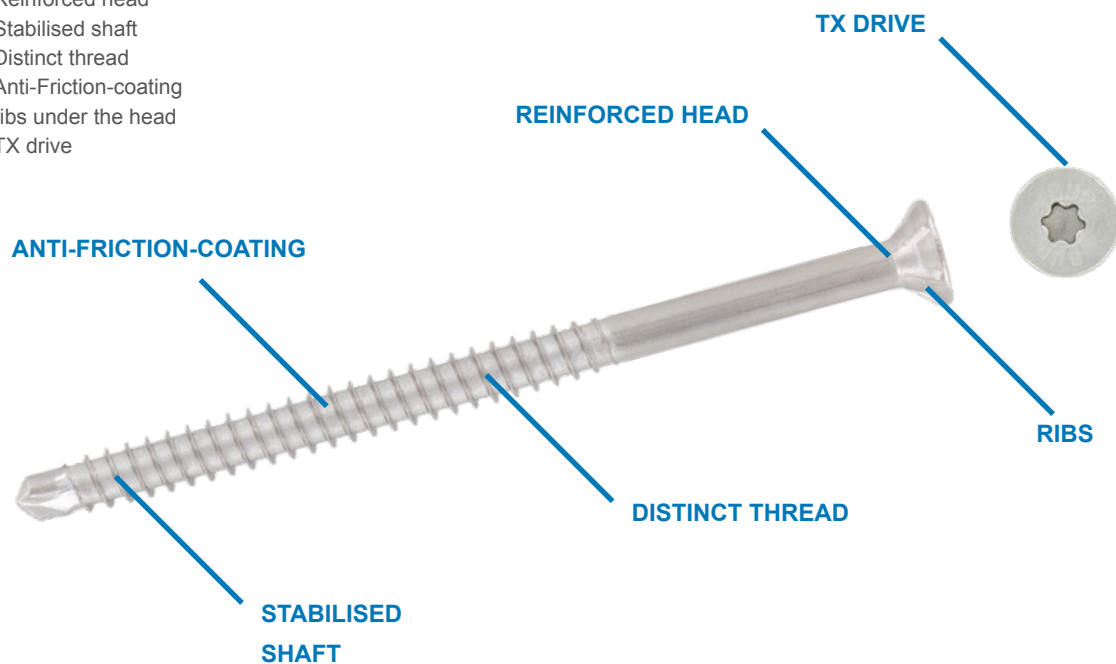

## PRODUCT BENEFITS:

### No predrilling

Predrilling is not needed, even in most hardwoods. But given the many different properties of hardwoods we would always recommend testing before application.

### Screws are not torn out

The stabilised shoulder and distinct thread geometry almost always prevent the screws from tearing out even in hardwoods.

### Wobble-free drive

The TX internal, multi-tooth drive allows easy and secure screw driving from setting to countersinking.

### Timber is not torn out

The drilling point relieves in the timber, thereby preventing cracks.

### Special smooth coating

Guarantees low screw in torques and less force is therefore needed.

### Visual appearance

The 6 milled ribs under the head ensure that the Super Drill timber construction screw is easily and cleanly countersunk.

# SP-DRILL

SP-Drill, CSK head timber screws with drilling point

Ideal for outdoor screw connections such as those in boarding, fences, balconies, steps, playground equipment, facades and terraces.

Ideal for screw connections in soft woods without pre-drilling.

Art.-Nr. 9044

Material: A2



## FEATURES:

drilling point  
ribs under the head  
TX drive

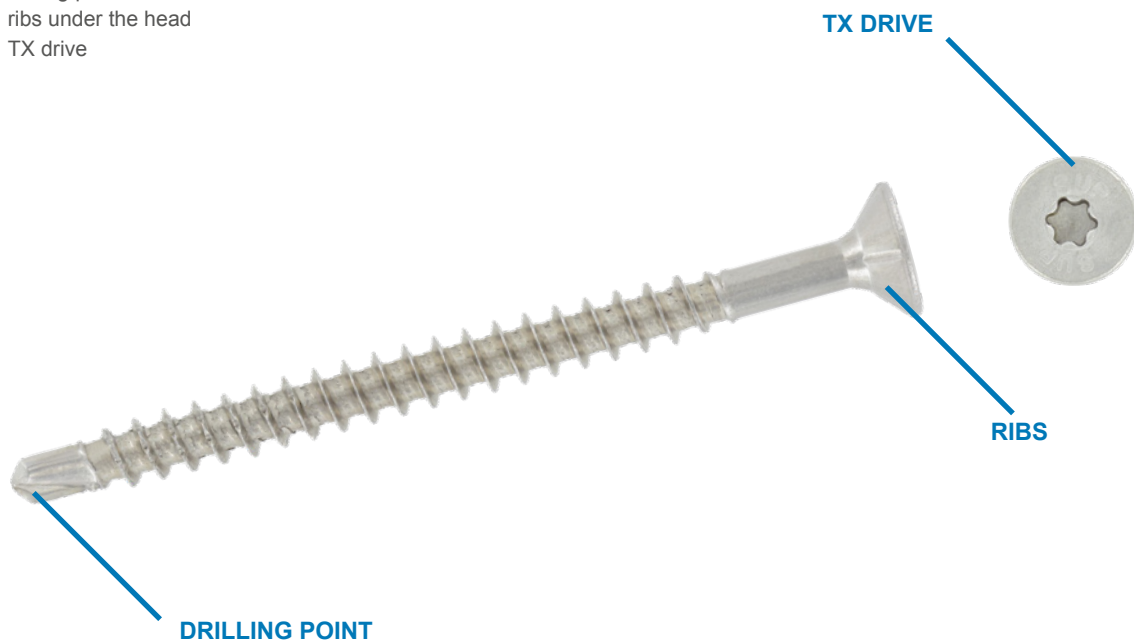

## PRODUCT BENEFITS:

### Wobble-free drive

The TX internal, multi-tooth drive allows easy and secure screw driving from setting to countersinking.

### Timber is not torn out

The drilling point relieves tension in the timber, thereby preventing cracks.

### No predrilling

Predrilling is not needed, even in most hardwoods. But given the many different properties of hardwoods we would always recommend testing the application.

# FLOORBOARD SCREWS TX

For all wood manufacturing companies (joinery, timber construction)  
Everywhere you lay floorboards (in-and outside)  
Optimum screw for low edge displacements

Art.-Nr. 9041  
Material: A2

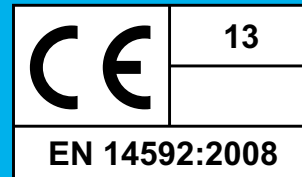

## FEATURES:

60° Ornamental head  
6 ribs under the head  
drilling point

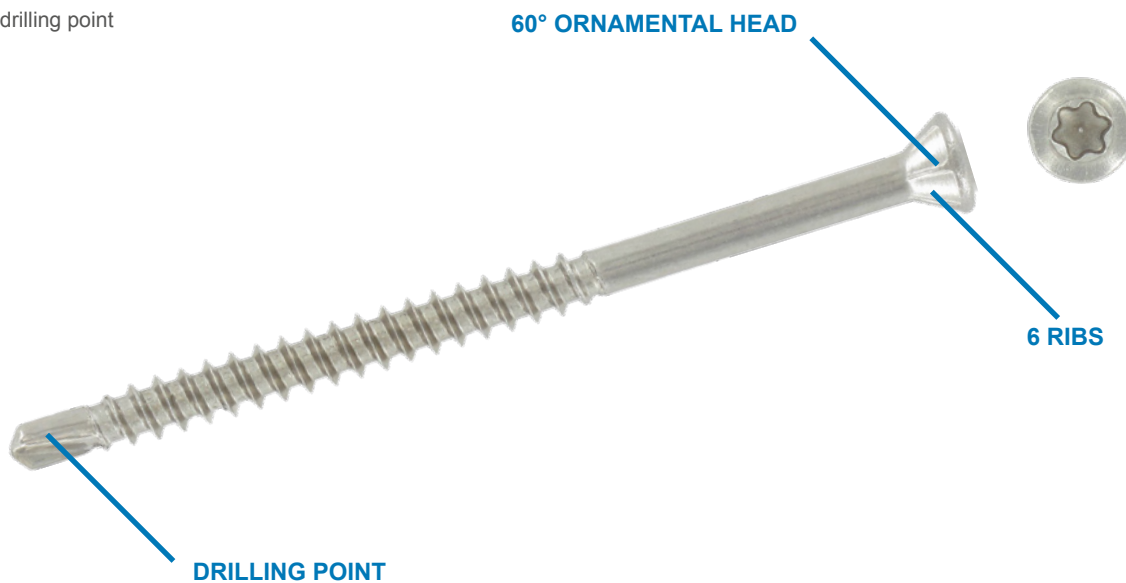

## PRODUCT BENEFITS:

### No predrilling

Predrilling is not needed, even in most hardwoods. But given the many different properties of hardwoods we would always recommend testing before application.

### Timber is not torn out

The drilling point relieves tension in the timber, thereby preventing cracks.

### Excellent optics

The decorative head and the milled ribs ensure a very good look.

### Wobble-free drive

The TX internal, multi-tooth drive allows easy and secure screw driving from setting to countersinking.

# QUADRA-SPEED TX

Timber screws CSK head with cutting point, Quadra Speed

Ideal for all companies involved in wood processing (carpenters, timber construction, facade construction), in all areas in which professional woodworkers are employed.

For chipboard, MDF and solid wood corner joints, for screw connections with short edge distances. Fastening fittings in the construction of wooden windows, cladding and balcony boards.

Art.-Nr. 9042

Material: A4

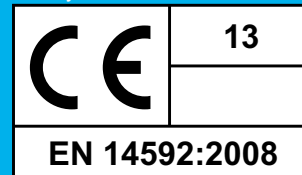

## FEATURES:

revolutionary square thread  
cutting point  
TX drive  
Secure hold for years to come  
ribs under the head

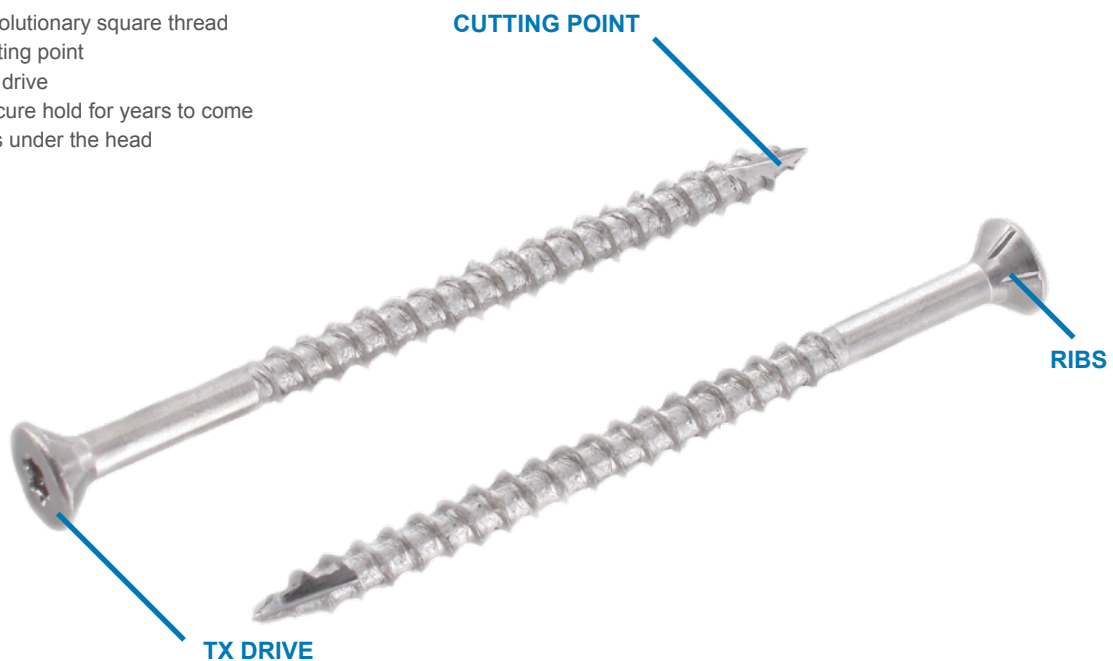

## PRODUCT BENEFITS:

### No predrilling

Predrilling is not needed in most cases. We do however always recommend testing the application.

### Timber is not torn out

The cutting point ensures accurate attachment without tearing out.

### No discolouring

The anti-corrosion special-grade steel prevents the timber and screw heads from discolouring.

### Quick fastening

Optimum screw in torques are achieved by the revolutionary square thread. Facades are therefore fastened reliably and speedily.

### The screw is not attacked

Stainless steel A4 prevents the screw being attacked by the wood blending (tannic acid)

### Excellent appearance

The decorative cap and the milled ribs ensure an excellent finish.

### Wobble-free drive

The TX internal, multi-tooth drive allows easy and secure screw driving from setting to countersinking.

# T-DRILL TX

also in  
Martensitic  
class C1 stainless steel  
**1.4006**

T-Drill, RSD CSK head terrace screws, cutting point

Ideal for all companies involved in wood processing (carpenters, timber construction) and all horticulturists and landscapers for fastening timbers and landing stages. Also the ideal solution for hardwoods such as Bankirai, Massaranduba, and many more.

Art.-Nr. 9043

Material: 1.4006/C1 = ETA-11/0283

Material: A2/A4 = EN 14592:2008

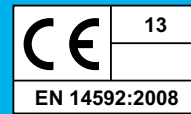

## FEATURES:

- Reinforced head
- milling ribs
- Stabilised shaft
- New kind of threaded flank arrangement
- cutting point
- ribs under the head
- TX drive
- Anti-Friction-coating

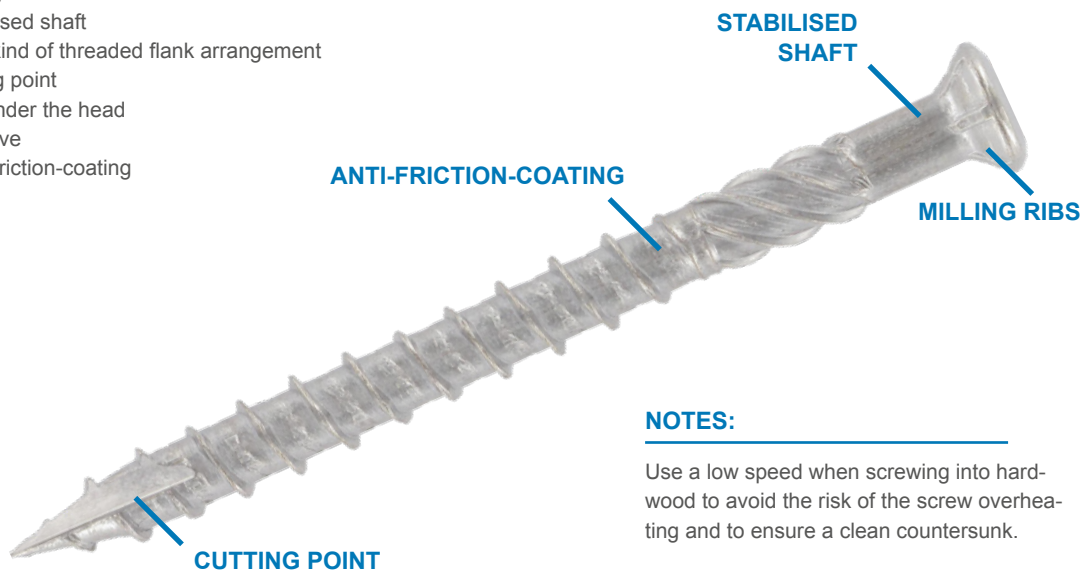

## NOTES:

Use a low speed when screwing into hardwood to avoid the risk of the screw overheating and to ensure a clean countersunk.

If working with problematic timbers, we recommend predrilling the component to be fastened ( $\emptyset$ -of screw= $\emptyset$ -drill diameter).

## PRODUCT BENEFITS:

### Milling ribs

The milling ribs ensure low screw-in torques even with high attachment parts.

### No predrilling

Predrilling is not needed in most cases. We do however always recommend testing the application.

### Timber is not torn out

The cutting point ensures accurate attachment on hardwood without tearing out.

### Wobble-free drive

The TX internal, multi-tooth drive allows easy and secure screw driving from setting to countersinking. New kind of threaded flanks. The screw that can feel.

### Great look

The milled ribs under the head ensure that the T-Drill timber construction screw is easily and cleanly countersunk.

# SK-DRILL TX

SK-DRILL, CSK head terrace screws, cutting point

Ideal for bolting timbers of Terrace on wooden structures, mainly in the Scandinavian region.

Art.-Nr. 9142  
Material: A2/A4

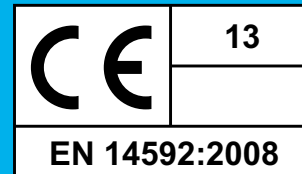

## FEATURES:

80° countersunk head  
ribs under the head  
cutting point  
coarse thread  
truncated thread

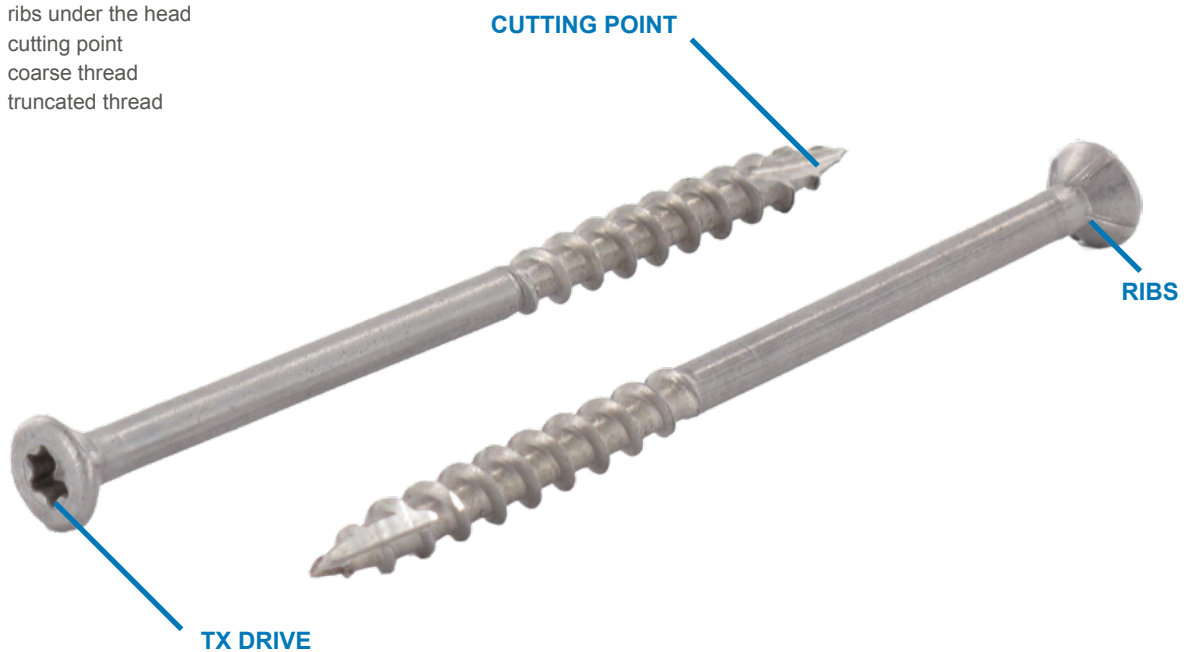

## PRODUCT BENEFITS:

### Timber is not torn out

The cutting point in the thread chamfer destresses the timber, thereby preventing cracks.

### No predrilling

Predrilling is not needed in most cases. We do however always recommend testing the application.

### No discolouring

The anti-corrosion specialgrade steel prevents the timber and screw heads from discolouring.

### Wobble-free drive

The TX internal, multi-tooth drive allows easy and secure screw driving from setting to countersinking.

### Great look

The four milled ribs under the head ensure that the SK-Drill is easily and cleanly countersunk.

# TBS-DRILL SEKO TX

TBS-Drill, a decking screw with a cutting notch, a small countersunk head and an additional retaining thread beneath the head.

Ideal for all companies involved in wood processing (carpenters, timber construction) and all horticulturists and landscapers for fastening timbers and landing stages. Also the ideal solution for hardwoods such as Bankirai, Massaranduba, and many more.

Art.-Nr. 9143  
Material: A2

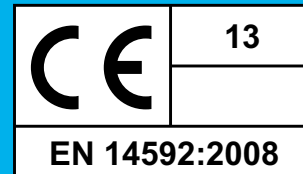

## FEATURES:

Small countersunk head (diameter just 7,5 mm)  
Additional thread under the head  
Stabilised shaft  
cutting point  
ribs under the head  
TX drive



## PRODUCT BENEFITS:

### No predrilling

Predrilling is not needed in most cases. We do however always recommend testing the application.

### Timber is not torn out

The cut tip ensures accurate attachment on hardwood without tearing out.

### Wobble-free drive

The TX internal, multi-tooth drive allows easy and secure screw driving from setting to countersinking.

### Great look

The four milled ribs under the head ensure that the TBS-Drill is easily and cleanly countersunk.



**OUR  
LOGISTICS  
IS YOUR  
AVAILABILITY!**

# RSD CSK HEAD TIMBER SCREWS, DRILLING POINT

Martensitic  
class C1 stainless steel  
**1.4006**

RSD csk head timber screws, drilling point, milling ribs

Ideal for all companies involved in wood processing (carpenters, timber construction) and all horticulturists and landscapers for fastening timbers and landing stages. Also the ideal solution for hardwoods such as Bankirai, Massaranduba, and many more.

Art.-Nr. 9241

Material: 1.4006/C1



## FEATURES

- 60° Ornamental head
- drilling point
- milling ribs
- ribs under the head
- TX drive
- Martensitic stainless steel hardened (1.4006)
- Anti-Friction-coating

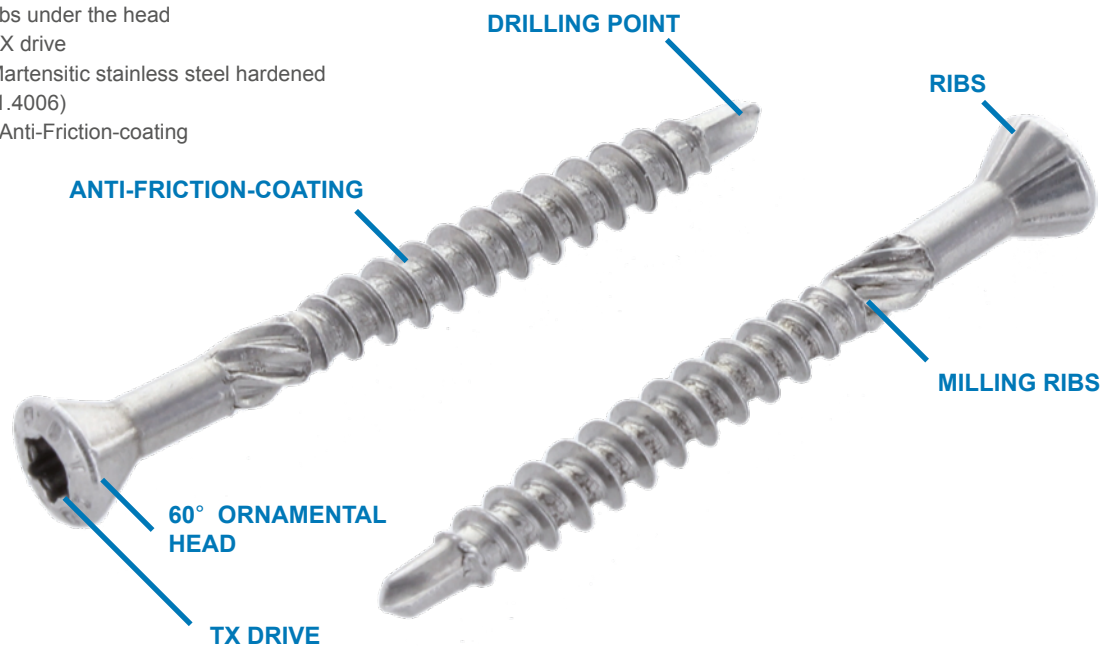

## PRODUCT BENEFITS:

### Milling ribs

The milling ribs ensure low screw-in torques even with high attachment parts.

### No predrilling

Predrilling is not needed in most cases. We do however always recommend testing the application.

### Wobble-free drive

The TX internal, multi-tooth drive allows easy and secure screw driving from setting to countersinking.

# RSD CSK HEAD TIMBER SCREWS, CUTTING POINT

also in  
Martensitic  
class C1 stainless steel  
**1.4006**

Timber screws RSD CSK head with cutting point, milling ribs  
Ideal for all companies involved in wood processing (carpenters, timber construction) and all horticulturists and landscapers for fastening timbers and landing stages. Also the ideal solution for hardwoods such as Bankirai, Massaranduba, and many more.

Art.-Nr. 9242  
Material: - A2/A4 (also burnished)  
- 1.4006/C1



## FEATURES:

- 60° Ornamental head
- cutting point
- milling ribs
- ribs under the head
- TX drive
- Anti-Friction-coating

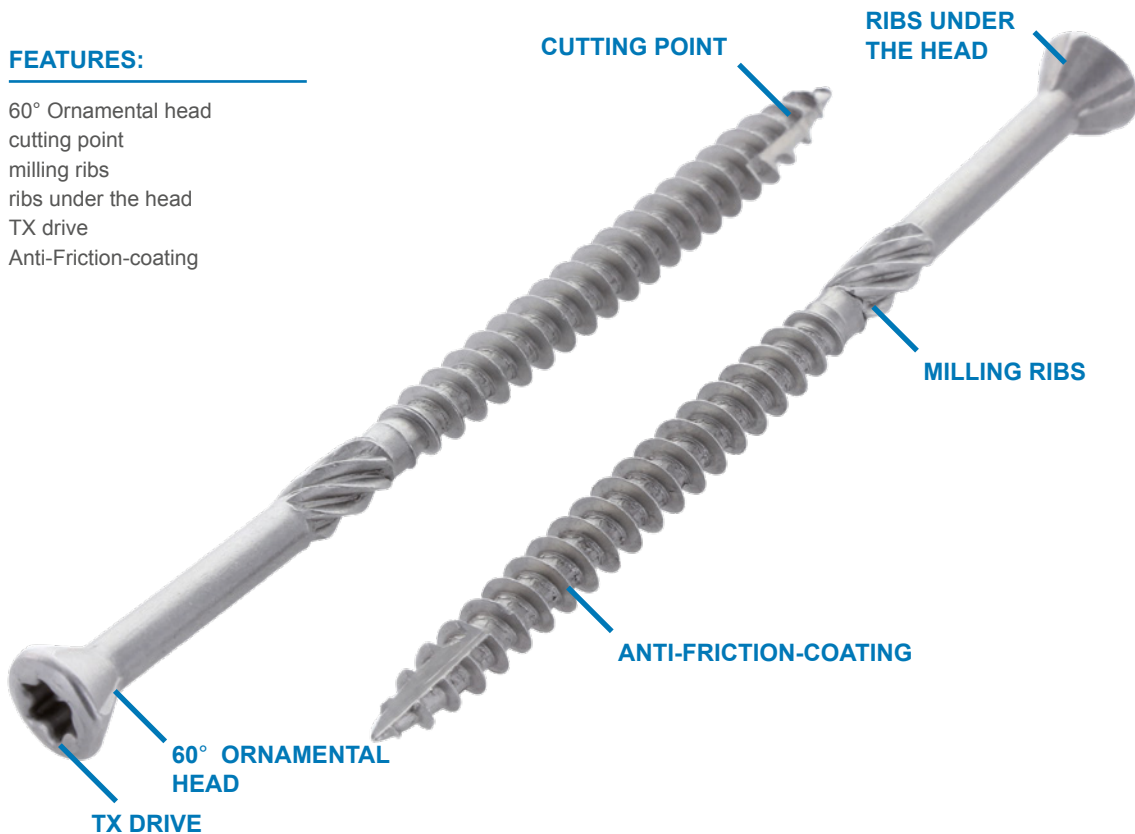

## PRODUCT BENEFITS:

### Milling ribs

The milling ribs ensure low screw-in torques even with high attachment parts.

### No predrilling

Predrilling is not needed in most cases. We do however always recommend testing the application.

### Wobble-free drive

The TX internal, multi-tooth drive allows easy and secure screw driving from setting to countersinking.

### Timber is not torn out

The cutting point ensures accurate attachment on hardwood without tearing out.

# TBS-DRILL, CYL. HEADTX

TBS-Drill, cyl. head terrace screws

Ideal for all companies involved in wood processing (carpenters, timber construction) and all horticulturists and landscapers for fastening timbers and landing stages. Also the ideal solution for hardwoods such as Bankirai, Massaranduba, and many more.

Art.-Nr. 9243

Material: A4/1.4006/C1

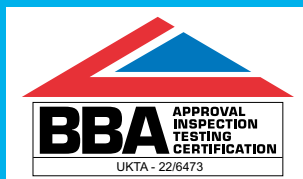

## FEATURES:

- Cylinder head
- Additional thread under the head
- Standard tip
- TX drive
- Anti-Friction-coating

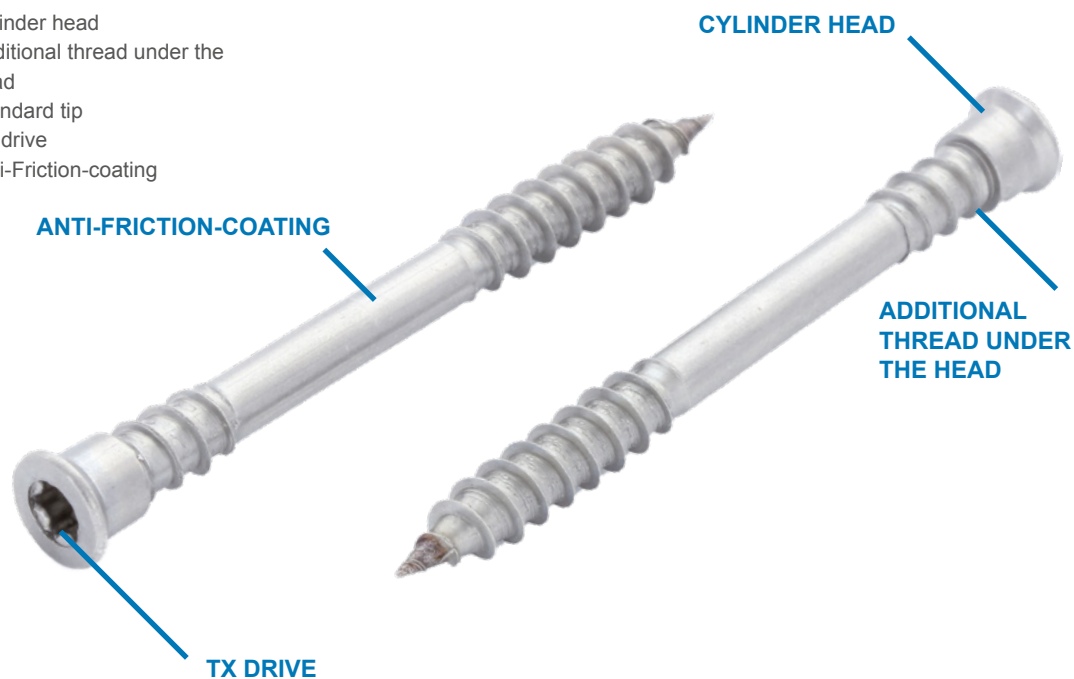

## PRODUCT BENEFITS:

### Wobble-free drive

The TX internal, multi-tooth drive allows easy and secure screw driving from setting to countersinking.

### Cylinder head

The wooden fibers are drawn into the material by the cylinder head with the implied countersunk by this special process.

### Under head thread

This terrace screws fixed the wood through the lower head screw, thereby preventing movement.

# SP-DRILL TX

Martensitic  
class C1 stainless steel  
**1.4006**

SP-Drill, CSK head timber screws with drilling point

Ideal for all companies involved in wood processing (carpenters, timber) and all gardeners and landscapers for connection of wooden structures. Cover formwork perfectly suitable also for example in facade for wall coverings.

Art.-Nr. 9244

Material: 1.4006/C1



## FEATURES:

- countersunk 90°
- drilling point
- ribs under the head
- TX drive
- Martensitic stainless steel hardened (1.4006)
- Anti-Friction-coating

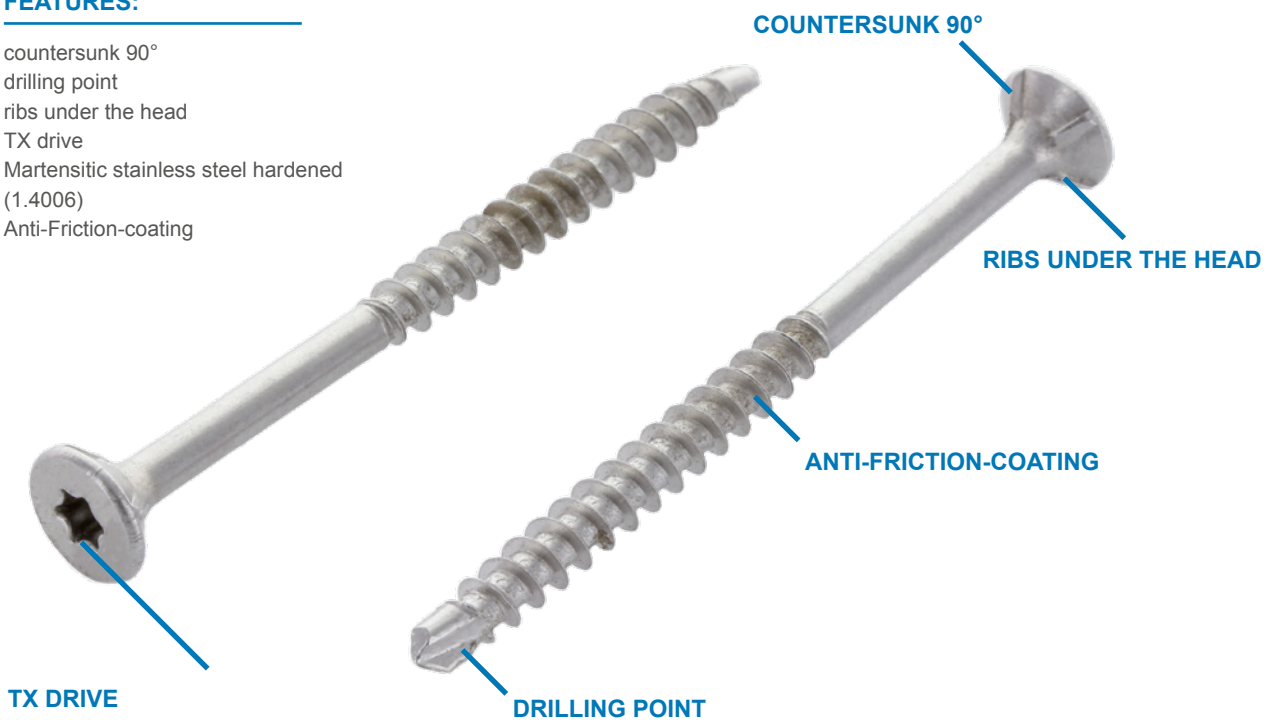

## PRODUCT BENEFITS:

### No predrilling

Predrilling is not needed in most cases. We do however always recommend testing the application.

### Wobble-free drive

The TX internal, multi-tooth drive allows easy and secure screw driving from setting to countersinking.

# TBS-DRILL TX

Martensitic  
class C1 stainless steel  
**1.4006**

TBS-Drill, cyl. head terrace screws, cutting point

Ideal for all companies involved in wood processing (carpenters, timber construction) and all horticulturists and landscapers for fastening timbers and landing stages. Also the ideal solution for hardwoods such as Bankirai, Massaranduba, and many more.

Art.-Nr. 9245

Material: 1.4006/C1



## FEATURES:

- Cylinder head
- milling ribs
- cutting point
- TX drive
- Martensitic stainless steel hardened (1.4006)
- Anti-Friction-coating

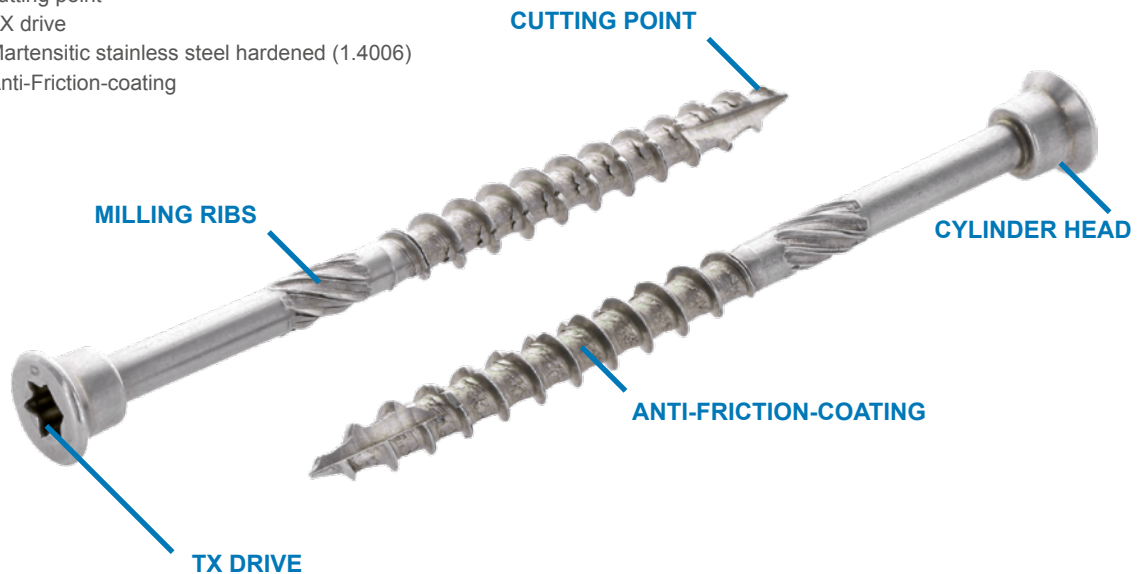

## PRODUCT BENEFITS:

### Milling ribs

The milling ribs ensure low screw-in torques even with high attachment parts.

### No predrilling

Predrilling is not needed in most cases. We do however always recommend testing the application.

### Timber is not torn out

The Cut tip ensures accurate attachment on hardwood without tearing out.

### Wobble-free drive

The TX internal, multi-tooth drive allows easy and secure screw driving from setting to countersinking.

### Cylinder head

no distant wooden fibers. The wooden fibers are drawn into the material by the cylinder head with the implied countersunk head. An optimal barefooted flooring originates by this special process.

# SP-DRILL WITH MILLING RIBS

Martensitic  
class C1 stainless steel  
**1.4006**

SP-Drill, CSK head timber screws, drilling point, milling ribs

Ideal for all companies involved in wood processing (carpenters, timber construction) and all horticulturists and landscapers for fastening timbers and landing stages. Also the ideal solution for hardwoods such as Bankirai, Massaranduba, and many more.

Art.-Nr. 9246

Material: 1.4006/C1



## FEATURES:

- countersunk 90°
- drilling point
- ribs under the head
- milling ribs
- TX drive
- Martensitic stainless steel hardened (1.4006)
- Anti-Friction-coating

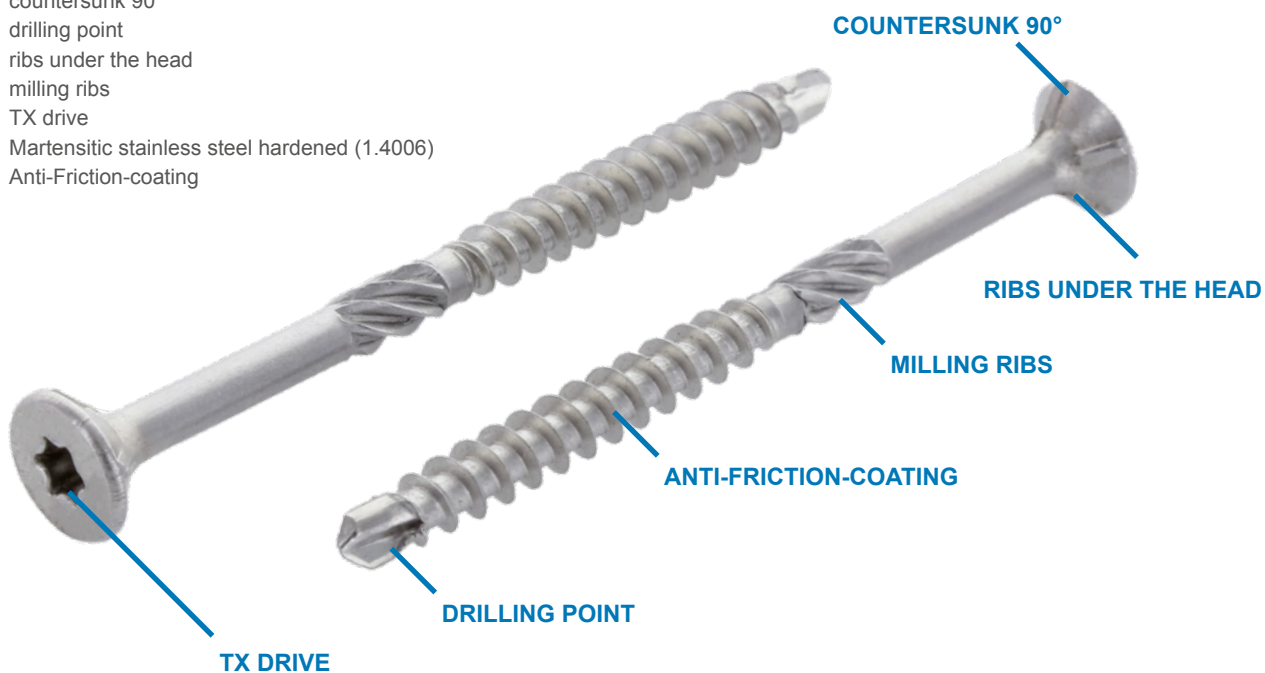

## PRODUCT BENEFITS:

### Milling ribs

The milling ribs ensure low screw-in torques even with high attachment parts.

### No predrilling

Predrilling is not needed in most cases. We do however alwaysw recommend testing the application.

### Wobble-free drive

The TX internal, multi-tooth drive allows easy and secure screw driving from setting to countersinking.

# CLADDING SCREWS

For securing profile sheets and fibre cement slabs to steel and aluminium substructures

Type A (with tip) / Type BZ (with cone point)

Art.-Nr. 9057 (Ø 16mm-sealing washer)  
Art.-Nr. 9059 (Ø 19mm-sealing washer)  
Art.-Nr. 9098 (Ø 22mm-sealing washer)  
Material: A2

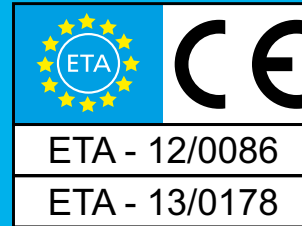

## VERSIONS:

### Type A

Coarse thread with tip for timber substructures and thin sheet metal < 3mm

### Type BZ

Fine thread with cone point for steel substructures > 3mm

### Sealing washer 16 / 19 / 22

Stainless steel sealing washers with vulcanised EPDM gasket

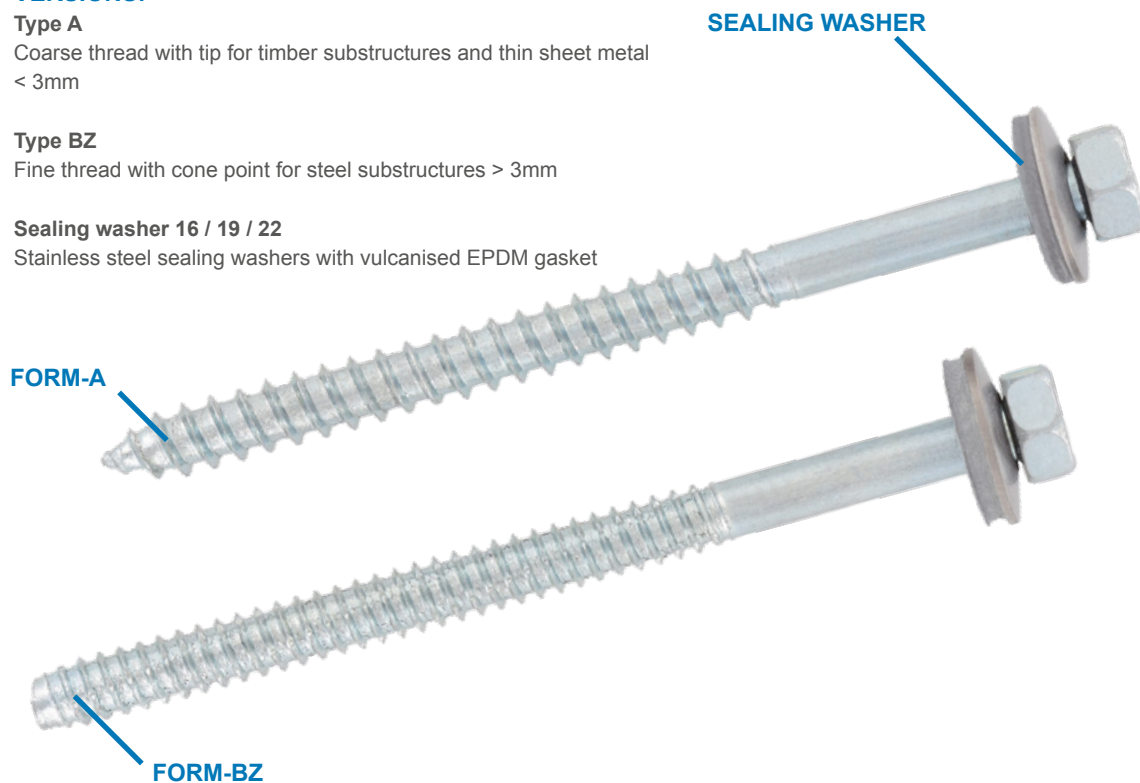

## PRODUCT BENEFITS:

### European Technical Approval ETA 12/0086

Fasteners for joining components in lightweight metal construction

### European Technical Approval ETA 13/0178 valid from L 75 mm

Thread-forming screws for joining sandwich panels to wooden or steel substructures

# DIN 931 / DIN 933 / DIN 934 ISO 4014 / ISO 4017 / ISO 4032

Standard bolts and nuts for steel and metal construction.  
Suitable for use in any application. Also available as ADW stock

Art.-Nr. 0931	ISO 4014
Art.-Nr. 0933	ISO 4017
Art.-Nr. 0934	ISO 4032

Material: A2/A4/special material



DIN 931  
ISO 4014



DIN 933  
ISO 4017



DIN 934  
ISO 4032

# DIN 976 / DIN 603 / ISO 4762

Standard bolts and nuts for steel and metal construction.  
Suitable for use in any application. Also available as ADW stock

Art.-Nr. 0976

Art.-Nr. 0603

Art.-Nr. 4762

Material: A2/A4/special material



DIN 976

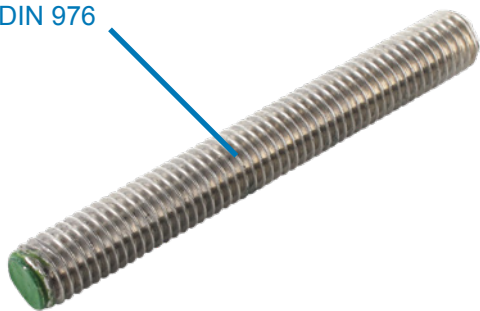

ISO 4762

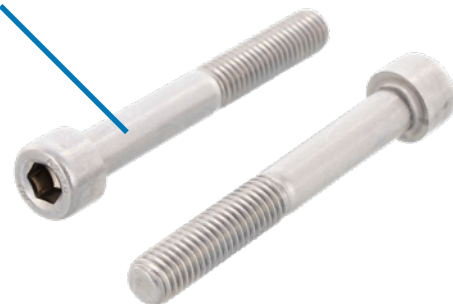

DIN 603

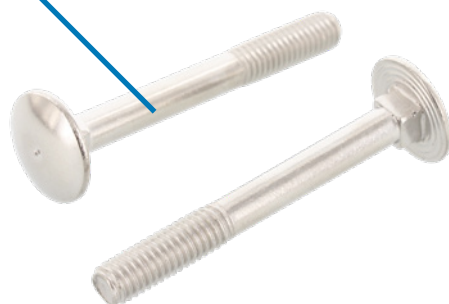

# ISO 10642 / ISO 7380-1 / ISO 7380-2

Standard bolts and nuts for steel and metal construction.  
Suitable for use in any application. Also available as ADW stock

Art.-Nr. 10642  
Art.-Nr. 73801  
Art.-Nr. 73802  
Material: A2/A4



ISO 10642

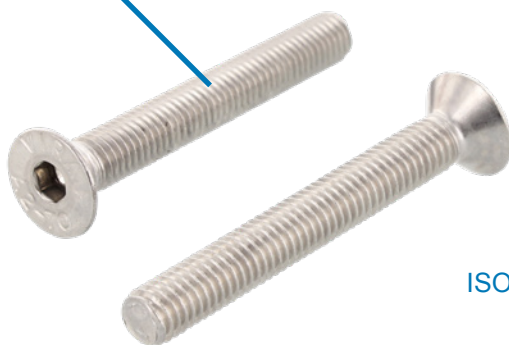

ISO 7380-1

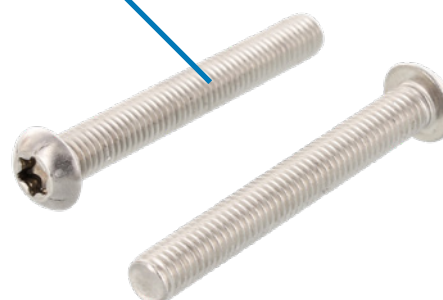

ISO 7380-2



# BI-METAL THIN SHEET SCREW

For thin-profiled panels, butt joints in steel and aluminum profiled sheets and the attachment of the domes on trapezoidal profiles. The optimum screw connection of trapezium holders (9032) on trapezium tin boards. BI-Metall - a special welding process joins the stainless steel screw to the hardened carbon steel tip

Recommended tightening torque for steel: about 3Nm, 1 Nm to 0.8 mm thickness.

Recommended tightening torque for aluminum: about 1Nm, 0.8 mm thickness under 0.5 Nm.

without washer  
Art.-Nr. 95052B20  
Material: A2/CV

without washer and fine thread  
Art.-Nr. 95062B20  
Material: A2/CV

with washer  
Art.-Nr. 95052B2  
Material: A2/CV

with washer and fine thread  
Art.-Nr. 95062B2  
Material: A2/CV



## FEATURES:

- 50% higher hold strengt
- 50% of saving of time
- less connection points urgently
- nearly no drilling filings

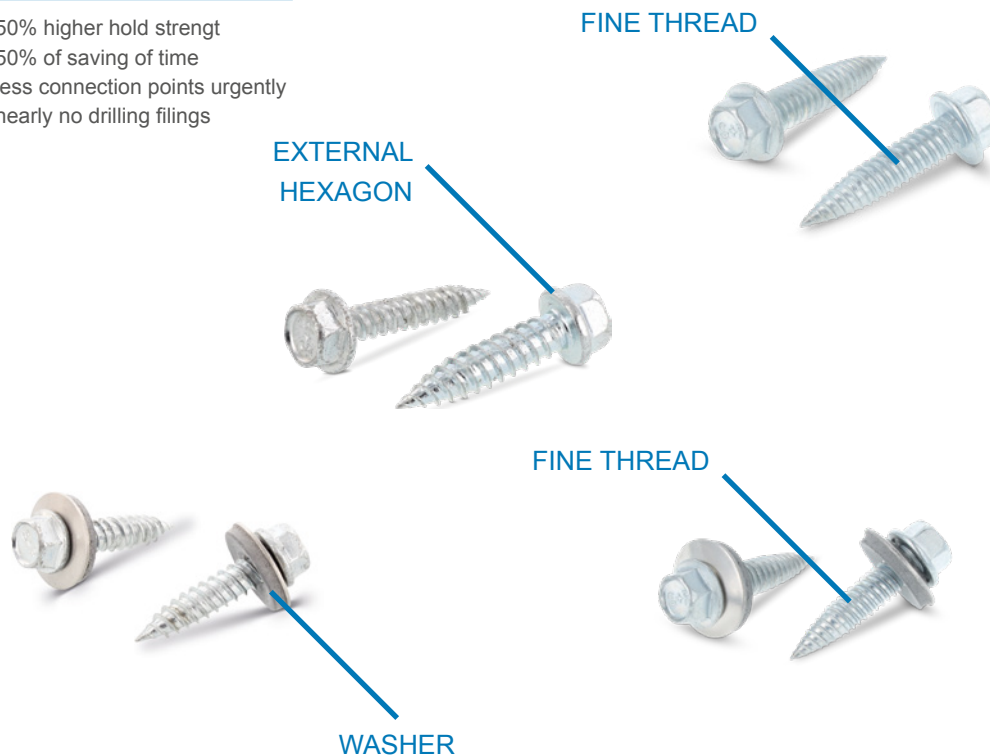

## PRODUCT BENEFITS:

### 1 work step

Drilling, shaping and joining in a single operation.

### Reduce costs

### No need to change tools

no drilling tools

# BI-Metal-Self drilling screws

For fastening steel profiled sheets to steel substructures, as well as aluminium profiled sheets and sandwich panels to aluminium or steel substructures

For joining profiled sheets and sandwich panels in lightweight construction

Art.-Nr.: 9504 - ETA-12/0086 / ETA-13/0178  
 9604 - ETA-12/0086  
 Material: A2/CV; A4/CV



## Selecting the screw

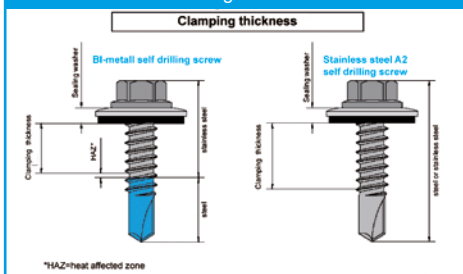

## Product name

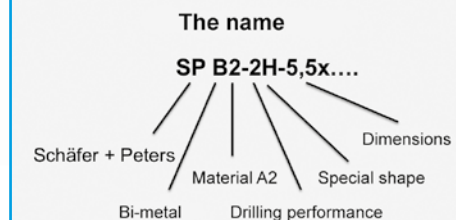

PRODUCT DESCRIPTION ON PAGES 36–39

# BI-METAL SELF-TAPPING SCREWS

- SP-B2-2-6,0
- SP-B2-2H-5,5
- SP-B2-2-4,8
- SP-B2-2-6,3

- SP-B2-3-5,5
- SP-B2-6-5,5
- SP-B2-6-6,3
- SP-A2-6-5,5



## BI-METAL SELF-TAPPING SCREW SP-B2-2-6,3

With a reduced drill point for sheet steel joints

### APPLICATION:

For sheet steel joints with a reduced drill point of 0.4–2.0 mm

### FEATURES:

BI Metal – A2 stainless steel with hardened drill tip  
 Stainless steel sealing washer with vulcanised EPDM seal  
 Sealing washer secured to prevent loss

Drilling capacity:

- Component I – 0.63 mm to 2.0 mm
- Component II – steel substructure 0.63 mm to 2.0 mm

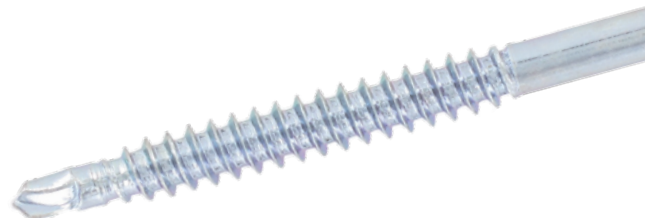

## BI-METAL SELF-TAPPING SCREW SP-B2-2H-5,5

For longitudinal bolted joints in steel and aluminium profiled sheets

### APPLICATION:

For longitudinal butt-joint fastening of steel and aluminium profiled sheets with a thickness of 0.4–1.5 mm

### FEATURES:

BI Metal – A2 stainless steel with hardened drill tip  
 With undercut beneath the screw head for longitudinal butt joints  
 Stainless steel washer with vulcanised EPDM seal  
 Washer fitted to prevent loss

Drill capacity TI + TII .... 1.25 mm + 1.25 mm





#### **A2 STAINLESS STEEL SELF-TAPPING SCREW SP-A2-6-5,5**

For bolting aluminium profiles to aluminium structures

##### **APPLICATION:**

For bolting aluminium profiles to aluminium structures with a thickness of 0.5–5.5 mm

##### **FEATURES:**

A2 stainless steel  
Sealing washer with vulcanised EPDM gasket  
Sealing washer fitted in a captive design  
Drilling capacity TI + TII ... 2.0 mm + 4.0 mm



#### **BI-METAL SELF-TAPPING SCREW SP-B2-2-6,0**

For profiled sheets with or without intermediate insulation on thin-walled steel, aluminium and timber substructures

##### **APPLICATION:**

For profiled sheets with or without intermediate insulation on thin-walled steel, aluminium and timber substructures of 0.5–2.0 mm

##### **FEATURES:**

BI Metal – A2 stainless steel with hardened drill tip  
Stainless steel sealing washer with vulcanised EPDM seal  
Sealing washer secured to prevent loss  
Drilling capacity TI + TII ... 1.0 mm + 1.0 mm



#### **BI-METAL SELF-TAPPING SCREW SP-B2-3-5,5**

For bolting steel profiled sheets to steel substructures

##### **APPLICATION:**

For fastening steel profiled sheets to steel substructures, and aluminium profiled sheets to aluminium or steel substructures with a thickness of 0.5–2.5 mm

##### **FEATURES:**

BI Metal – A2 stainless steel with hardened drill tip  
Stainless steel sealing washer with vulcanised EPDM seal  
Sealing washer secured to prevent loss  
Drilling capacity TI + TII ... 1.0 mm + 2.5 mm

# BI-METAL SELF-TAPPING SCREWS

- SP-B2-2-6,0
- SP-B2-2H-5,5
- SP-B2-2-4,8
- SP-B2-2-6,3
- SP-B2-3-5,5

- SP-B2-6-5,5
- SP-B2-6-6,3
- SP-B2-12-5,5
- SP-A2-6-5,5



## BI-METAL SELF-TAPPING SCREW SP-B2-6-6,3

For bolting steel or aluminium profiled sheets to steel substructures

### APPLICATION:

For fastening steel profiled sheets to steel substructures and aluminium profiled sheets to aluminium or steel substructures with a thickness of 0.5–6.0 mm

### FEATURES:

BI-Metal – A2/A4 stainless steel with hardened drill bit  
Stainless steel sealing washer with vulcanised EPDM seal  
Sealing washer fitted to prevent loss  
Drilling capacity TI + TII ....1.0 + 5.0



#### **BI-METAL SELF-TAPPING SCREW SP-B2-2-4,8**

With a reduced drill point for sheet steel joints

##### **APPLICATION:**

For sheet steel joints with a reduced drill point of 0.4–2.0 mm

##### **FEATURES:**

BI-Metall – A2 stainless steel with hardened drill tip

Stainless steel sealing washer with vulcanised EPDM seal

Sealing washer secured to prevent loss

Drilling capacity:

Component I – 0.63 mm to 2.0 mm

Component II – steel substructure 0.63 mm to 1.5 mm

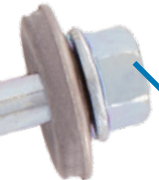

#### **BI-METAL SELF-TAPPING SCREW SP-B2-6-5,5**

For bolting steel or aluminium profiled sheets to steel sub-structures

##### **APPLICATION:**

For fastening steel profiled sheets to steel substructures, as well as aluminium profiled sheets and sandwich panels to aluminium or steel substructures with a thickness of 1.5–5.0 mm

##### **FEATURES:**

BI Metal – A2 stainless steel with hardened drill tip

Stainless steel sealing washer with vulcanised EPDM seal

Sealing washer secured to prevent loss

Drilling capacity TI + TII ... 2.0 mm – 4.0 mm



#### **BI-METAL SELF-TAPPING SCREW SP-B2-12-5,5**

For bolting steel or aluminium profiled sheets to steel sub-structures

##### **APPLICATION:**

For fastening steel profiled sheets to steel substructures (4.0 mm – 12.0 mm) and aluminium profiled sheets and sandwich panels to aluminium or steel substructures (from 4.0 mm)

##### **FEATURES:**

BI Metal – A2 stainless steel with hardened drill tip

Stainless steel sealing washer with vulcanised EPDM seal

Sealing washer secured to prevent loss

Drilling capacity TI + TII ... 2.0 mm + 10.0 mm

# BOLT ANCHOR BOZ

Ideal for outdoor bolting applications on brackets, railings, shelving, facades, cable trays, steel beams and window grilles.

For cracked and non-cracked concrete

Art.-Nr. 9004  
Material: A4



Fire safety  
tested

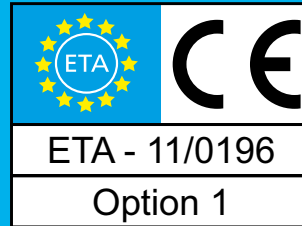

## FEATURES:

- Time-saving push-through assembly
- Maximum load bearing capacity at extremely low centre and edge distances
- Can be loaded straight away
- Optical settlement check

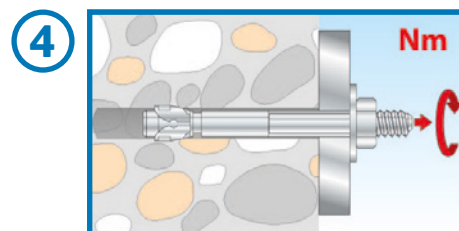
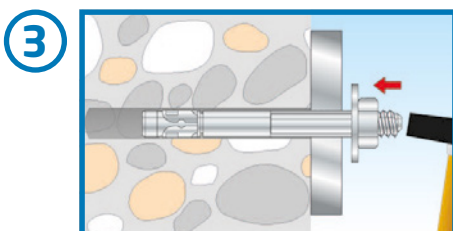
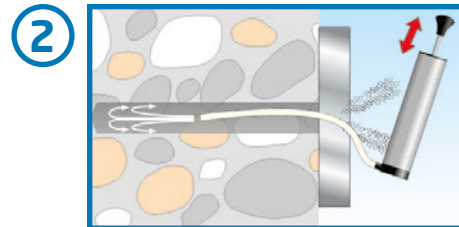
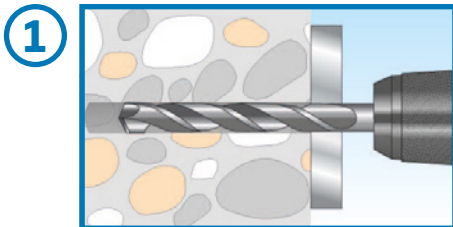

# CONCRETE BOLTS BS

Ideal for outdoor screw connections such as substructures, construction of rails, bridges or fences, signs, cabinets and solar systems.

For cracked and non-cracked concrete  
Fitted with carbide tips in a hexagonal shape,  
with a countersunk head and as a stud anchor version

Art.-Nr. 9001  
Material: A4



Fire safety  
tested



## FEATURES:

Tested for fire protection  
Hex drive  
carbide-tipped

### COUNTERSUNK CONCRETE BOLTS

Can be countersunk cleanly and  
flush with the material



### HEXAGON HEAD CONCRETE BOLTS

Looks good with the familiar wrench sizes



### PAN HEAD CONCRETE BOLTS

Elegant round head  
with the familiar TX sizes



### CONCRETE SCREW FLOOR ANCHOR

Ideal for installation thanks to the M12 metric  
connection thread

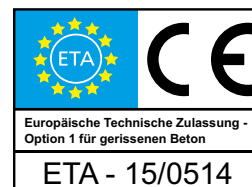

## PRODUCT BENEFITS:

#### Good build quality

Optimal thread geometry ensures low tightening torques and therefore minimal effort.

#### Cut the thread into the concrete - install without dowels

#### Small centre-to-centre and edge-to-edge distances

#### Cost-effective

Direct installation reduces working time by up to 50%.

# SOLAR FASTENER TYPE A

For timber substructures

Type: Type A (with tip)

Material: A2 stainless steel

Drive: Hex socket

Finish: Special anti-seize coating

Application: For securing photovoltaic and solar installations

Art.-Nr. 9182...84

Material: A2

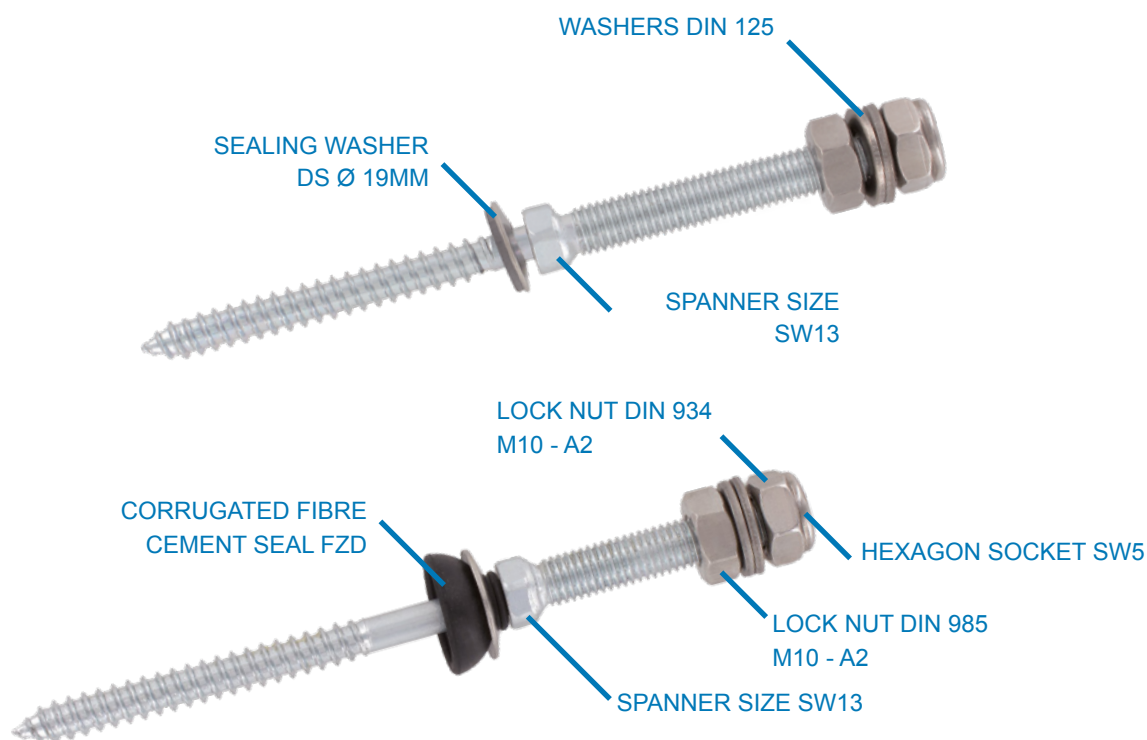

Corrugated fibre cement

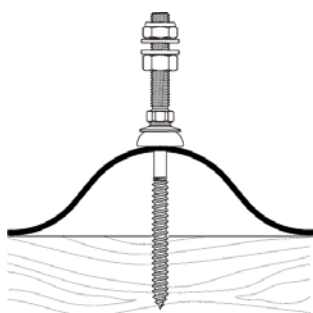

Trapezoidal profile and sandwich panel

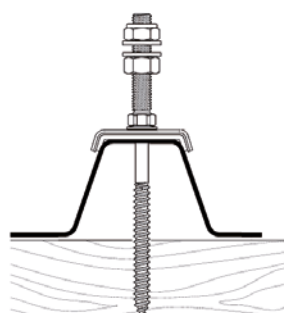

Corrugated profile and sandwich panel

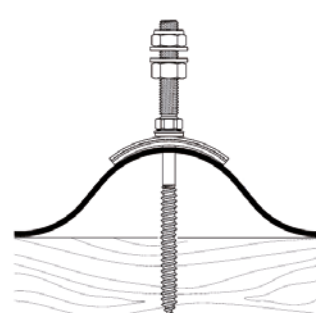

# SOLAR FASTENER TYPE BZ

For steel substructures

Type: BZ (with shank)  
 Material: A2 stainless steel  
 Drive: Hex socket  
 Finish: Special anti-seize coating  
 Application: For securing photovoltaic and solar systems

Art.-Nr. 9182...80  
 Material: A2

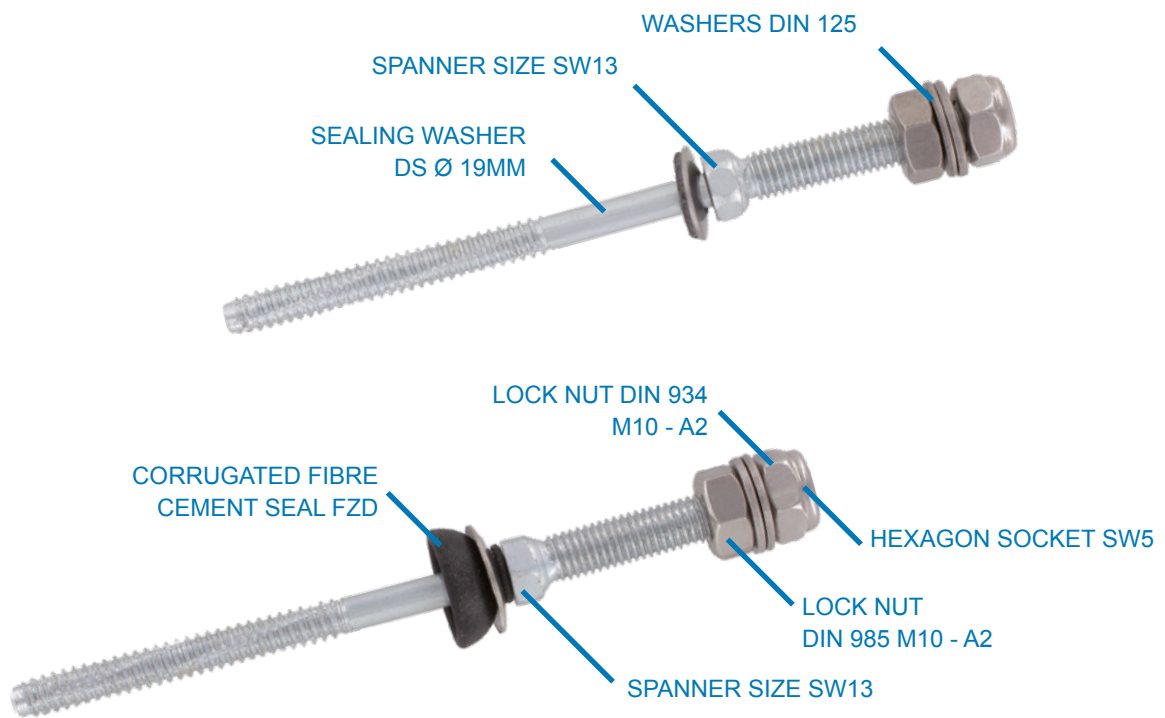

Corrugated fibre cement

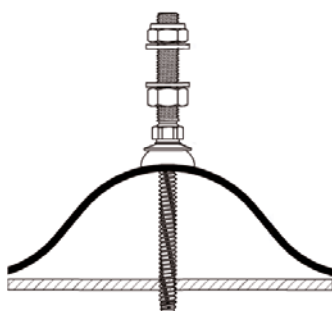

Trapezoidal profile and sandwich panel

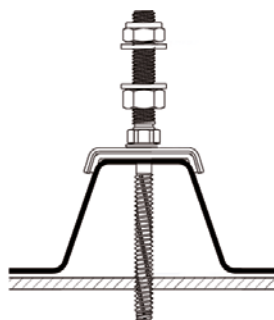

Corrugated profile and sandwich panel

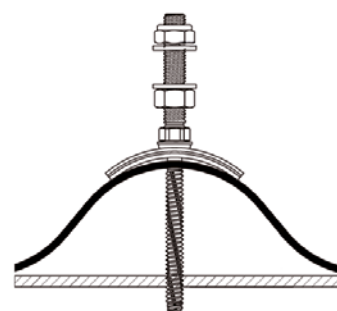

# HANGER BOLTS

For mounting photovoltaic and solar systems on wooden substructures  
Various designs and configurations

Art.-Nr. 9082  
Material: A2/A4



## HANGER BOLTS WITH FLANGE NUTS & EPDM GASKETS

With hex drive SW7 (M10) and hex drive SW9 (M12),  
Fully assembled in accordance with DIN 6923, with EPDM seal  
Material: A2 stainless steel

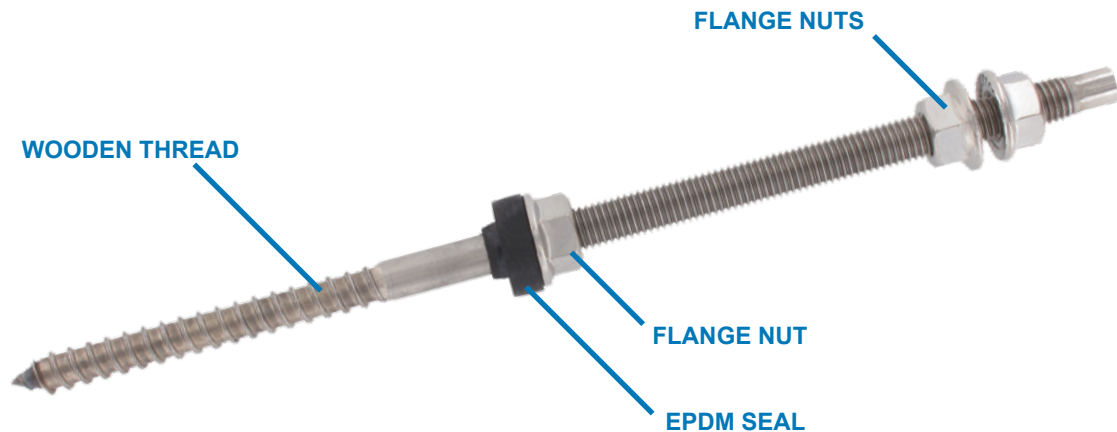

## HANGER BOLTS WITH NUTS, EPDM GASKETS AND WASHERS

With hex drive SW7 (M10) and hex  
drive SW9 (M12),  
Fully assembled with DIN 125, DIN  
9021 (M10),  
DIN 934, EPDM seal  
Material: A2 stainless steel



## STUD BOLTS WITH NUTS & EPDM GASKET & ADAPTER PLATE

With hex drive SW7 (M10) and hex  
drive SW9 (M12),  
Fully assembled with adapter plate  
82x40x5, 11 mm slotted hole,  
DIN 6923, EPDM seal  
Material: A2 stainless steel



## HANGER BOLTS WITH EXTERNAL HEXAGON

With hex drive SW7 (M10) and  
hex drive SW9 (M12),  
Material: A2 stainless steel



# UNIVERSAL BRACKETS FOR METAL SHEET ROOFS

For various trapezium plates with or without between insulation  
Perfect fastening together with the thin sheet screw

Application area: Solar

Art.-Nr. 9032  
Material: A2



## FEATURES:

Variable for all sizes of trapezium plates  
Fixing through self-adhesive strip  
Height-adjustable



## PRODUCT BENEFITS:

**Perfect sealing**  
because of self-adhesive strip on the plate

**Only 4 fixing points**  
with bi-metal self-drilling screws for thin plates

**only 1 tool necessary**  
DIN 603 M 8X25

**Flange nut with serration**  
DIN 6923

**No fixing problems**  
on different types of trapezium plates

# WE SET STANDARDS IN QUALITY, SCOPE OF DELIVERY AND SERVICE

- A trusted and innovative partner since 1982.
- With over 32 000 high-quality fastening products, we are a market leader in stainless steel fasteners.
- Constant product range expansion – in response to market developments and customer requirements.
- We set new standards in the areas of quality management and state of the art logistics.
- Our motivation, warehouse capacity and an experienced team are at your service.
- Fast delivery is a matter of course with us.
- Our company is DIN EN ISO 9001: 2015 certified.
- We combine quality and service – for connections that are made to last.



# Allgemeine Verkaufs- und Lieferbedingungen der Schäfer + Peters GmbH (künftig auch als „S + P“ bezeichnet) Stand 10/2022

## I. Geltungsbereich

1. Die nachstehenden Verkaufsbedingungen gelten für alle zwischen dem Käufer und S + P geschlossenen Verträge über die Lieferung von Waren und damit in Verbindung stehenden Leistungen (wie z.B. Beratungsleistungen oder Auskünfte), soweit es sich bei dem Käufer um ein Unternehmen, eine juristische Person des öffentlichen Rechts oder ein öffentlich-rechtliches Sondervermögen handelt. Aufträge werden ausschließlich auf der Grundlage nachfolgender Bedingungen ausgeführt. Das Angebot, die Angebotsannahme, die Auftragsbestätigung sowie der Verkauf jeglicher Produkte unterliegen den vorliegenden Bedingungen. Entgegenstehende oder abweichende Bedingungen des Käufers erkennen wir nicht an, es sei denn, wir hätten ausdrücklich ihrer Geltung zugestimmt. Dieses Zustimmungserfordernis gilt in jedem Fall, insbesondere auch dann, wenn wir in Kenntnis entgegenstehender oder abweichender Bedingungen des Käufers die Bestellung des Käufers vorbehaltlos ausführen.
2. In den Verträgen sind alle Vereinbarungen, die zwischen dem Käufer und S + P zur Ausführung der Kaufverträge bis zum Zeitpunkt des jeweiligen Vertragsschlusses getroffen wurden, in Textform niedergelegt. Die Wirksamkeit nachträglich im Einzelfall getroffener Individualvereinbarungen bleibt unberührt.
3. Soweit S + P und der Käufer eine Rahmenvereinbarung getroffen haben, gelten diese Allgemeinen Verkaufsbedingungen sowohl für diese Rahmenvereinbarung als auch für den einzelnen Lieferungs- bzw. Kaufauftrag.
4. Die Allgemeinen Verkaufsbedingungen gelten auch für alle künftigen Geschäftsbeziehungen, auch wenn sie nicht noch einmal ausdrücklich vereinbart werden.

## II. Angebot und Vertragsschluss

1. Eine Bestellung des Käufers, welche als rechtsverbindliches Angebot zum Abschluss eines Kaufvertrages zu qualifizieren ist, können wir innerhalb von zwei Wochen nach unserer Wahl durch Übersendung einer Auftragsbestätigung oder durch vorbehaltlose Erbringung der bestellten Lieferungen oder Leistungen annehmen.
2. Unsere Angebote sind freibleibend und unverbindlich, es sei denn, dass wir diese ausdrücklich als verbindlich bezeichnen haben. Angaben über unsere Waren (insbesondere technische Daten, Maße, Leistungs- und Verbrauchsdaten sowie die Beschreibungen in den jeweiligen Produktinformationen oder Werbematerialien u.a.) sind nur ungefähr und annähernd maßgeblich, soweit nicht die Verwendbarkeit zum vertraglich vorgesehenen Zweck eine genaue Übereinstimmung voraussetzt; sie sind keine garantierte Beschaffenheit, es sei denn, die Garantie erfolgt ausdrücklich und in Textform.
3. An allen Abbildungen, Kalkulationen, Zeichnungen sowie anderen Unterlagen behalten wir uns unsere Eigentums-, Urheber- sowie sonstige Schutzrechte vor. Der Käufer darf diese Gegenstände, unabhängig davon, ob wir sie als vertraulich gekennzeichnet haben, nur mit unserer Einwilligung in Textform als solche oder inhaltlich an Dritte weitergeben, sie bekannt geben, selbst oder durch Dritte nutzen oder vervielfältigen.
4. Angaben zu aktuellen Lagerbeständen sind stets unverbindlich. Werden Bestände dem Kunden mitgeteilt, so handelt es sich hierbei um speziell für Kunden- oder Absatzgruppen vorgehaltene Bestände, die nicht mit dem tatsächlichen Bestand identisch sein müssen.

## III. Zahlungsbedingungen

1. Unsere Preise gelten für den in den Auftragsbestätigungen aufgeführten Leistungs- und Lieferumfang. Mehr- oder Sonderleistungen werden gesondert berechnet. Die Preise gelten ab Werk Öhringen zuzüglich Verpackung, Zoll, Versicherung und im Einzelfall zusätzlich anfallender Abgaben, wenn nichts anderes festgelegt wurde. In unseren Preisen ist die gesetzliche Mehrwertsteuer nicht eingeschlossen. Diese werden wir in der gesetzlichen Höhe am Tage der Rechnungsstellung in der Rechnung gesondert ausweisen.
2. Soweit nicht abweichend vereinbart, sind Rechnungen innerhalb von 30 Tagen ab Rechnungsdatum und Lieferung ohne Abzug zur Zahlung fällig. Bei Zahlungen innerhalb von 10 Tagen ab Rechnungsdatum, gewähren wir Skonto von 2%, es sei denn der Käufer befindet sich mit weiteren Zahlungsverpflichtungen uns gegenüber im Zahlungsverzug. Eine Zahlung gilt erst dann als erfolgt, wenn wir über den Betrag verfügen können. Im Falle von Scheckzahlungen gilt die Zahlung erst als erfolgt, wenn der Scheck eingelöst wird.
3. Zahlt der Käufer nicht innerhalb der vorgeannten Frist, so gerät er in Zahlungsverzug, ohne dass es einer erneuten Zahlungsaufforderung bedarf. Im Falle des Zahlungsverzugs ist der Kaufpreis zu dem für Unternehmer gesetzlich geltenden Verzugszinssatz zu verzinsen. Weitergehende Ansprüche bleiben vorbehalten. Leistet der Käufer auch auf eine nochmalige Zahlungsaufforderung nicht, so sind wir dazu berechtigt, alle gegenüber dem Käufer bestehenden Verbindlichkeiten, insbesondere auch gestundete oder in Raten zu zahlende Beträge, sofort fällig zu stellen und etwaige weitere Lieferungen zu versagen.
4. Der Käufer ist zur Aufrechterhaltung und/oder Zurückbehaltung nur berechtigt, wenn die Gegenforderungen rechtskräftig festgestellt sind, von uns anerkannt wurden, unstreitig sind oder wenn die Gegenforderungen aus demselben konkreten Vertragsverhältnis wie die Hauptforderung herrühren und zu dieser in einem Gegenseitigkeitsverhältnis stehen.
5. Soweit S + P dem Käufer Ratenzahlung gewährt hat, wird der noch bestehende Restbetrag dann insgesamt zur Zahlung fällig, wenn der Käufer mit der Zahlung einer Rate länger als 8 Tage in Verzug gerät.
6. Preisänderungen sind zulässig, wenn zwischen Vertragsabschluss und vereinbartem Liefertermin mehr als vier Monate vergangen sind und die Preisänderung auf eine aktuelle Kostensteigerung zurückzuführen ist, welche wir nicht zu vertreten haben. Eine Kostensteigerung liegt vor, wenn sich bei zur Lieferung die Löhne, die Materialkosten, die Transportkosten, Transportnebenkosten oder die Vertriebskosten erhöhen. Dasselbe gilt, wenn sich Zölle erhöhen bzw. ein Zoll eingeführt wird oder sich Kostenänderungen aufgrund von Preiserhöhungen von Vorlieferanten oder wegen Wechselkursschwankungen ergeben. S + P ist in diesen Fällen berechtigt, den Preis angemessen entsprechend den Kostensteigerungen zu erhöhen.

## IV. Liefer- und Leistungszeit, Höhere Gewalt, Haftung bei Lieferverzug

1. Liefertermine oder Fristen, die nicht ausdrücklich als verbindlich vereinbart oder ausdrücklich verbindlich von uns zugesagt worden sind, sind ausschließlich unverbindliche Angaben. Sie gelten nur annäherungsweise und beschreiben den voraussichtlichen Liefertermin. Hiervon abweichende Vereinbarungen oder Zusagen über eine verbindliche Lieferzeit müssen ausdrücklich und in Textform erfolgen. Die Lieferzeit beginnt erst dann zu laufen, wenn der Käufer die seinerseits geschuldeten Mitwirkungshandlungen ordnungsgemäß und vollständig erbracht hat.
2. Erhalten wir aus von uns nicht zu vertretenden Gründen Lieferungen oder Leistungen unserer Unterlieferanten oder von Subunternehmern trotz ordnungsgemäßer Eindeckung nicht, nicht richtig oder nicht rechtzeitig oder treten Ereignisse höherer Gewalt ein, so werden wir unseren Kunden rechtzeitig in Textform informieren und uns nach besten Kräften bemühen, die Liefer- oder Leistungsstörung oder die höhere Gewalt zu beheben und in ihren Auswirkungen soweit wie möglich zu beschränken. In diesem Fall sind wir berechtigt, die Lieferung bzw. Leistung um die Dauer einer nur vorübergehenden Behinderung herauszuschieben oder im Falle einer wesentlichen Behinderung von nicht nur vorübergehender Dauer wegen des noch nicht erfüllten Teils vom Vertrag ganz oder teilweise zurückzutreten, soweit wir unserer vorstehenden Informationspflicht nachgekommen sind und nicht das Beschaffungsrisiko bzw. Herstellungsrisiko übernommen haben. Der höheren Gewalt stehen gleich sonstige bei Vertragsabschluss nicht vorhersehbare Ereignisse wie rechtmäßige Streiks oder Aussparungen, behördliche Eingriffe, Energie- und Rohstoffknappheit, unverschuldete Transportengpässe, unverschuldete Betriebsbehinderungen zum Beispiel durch Feuer, Wasser und Maschinenschäden, unerwartet auftretende Pandemien oder Epidemien, kriegs- und kriegsähnliche Handlungen, Wirtschaftssanktionen und alle sonstigen Behinderungen, die bei objektiver Betrachtungsweise nicht von uns schuldhaft herbeigeführt worden sind. Verzögert sich die Lieferung oder Leistung in Folge eines der vorstehend in Satz 1 und 3 genannten Fälle um mehr als einen Monat, so sind sowohl wir als auch der Kunde - unbeschadet des Fristsetzungserfordernisses für den Kunden und unter Ausschluss jeglicher Schadensersatzansprüche - berechtigt, hinsichtlich der von den Lieferstörungen betroffenen Menge vom Vertrag zurückzutreten. Zum Rücktritt vom gesamten Vertrag ist der Kunde berechtigt, wenn ihm die Annahme einer Teillieferung unzumutbar ist.
3. In jedem Falle geraten wir erst nach Ablauf einer vom Kunden gesetzten angemessenen Nachfrist in Lieferverzug, es sei denn, es handelt sich um ein Fixgeschäft im Sinne von § 286 Abs. 2 Nr. 4 BGB oder von § 376 HGB.
4. Unsere gesetzlichen Rechte, insbesondere bei einem Ausschluss der Leistungspflicht (z. B. aufgrund Unmöglichkeit oder Unzumutbarkeit der Leistung und/oder Nacherfüllung), bleiben unberührt. Schadensersatzansprüche aus Lieferverzug sind ausgeschlossen, soweit sie nicht auf einem vorsätzlichen, arglistigen oder grob fahrlässigen Handeln unsererseits oder unserer Erfüllungsgehilfen oder auf der schuldhaften Verletzung wesentlicher Vertragspflichten beruhen. Wesentlich sind diejenigen Vertragspflichten, die vertragswesentliche Rechtspositionen des Kunden schützen, die ihm der Vertrag nach seinem Inhalt und Zweck gerade zu gewähren hat; wesentlich sind ferner solche Vertragspflichten, deren Erfüllung die ordnungsgemäße Durchführung des Vertrages überhaupt erst ermöglicht und auf deren Einhaltung der Vertragspartner regelmäßig vertraut und auch vertrauen darf.

Der Haftungsausschluss gilt nicht für Schäden, welche aus der Verletzung des Lebens, des Körpers oder der Gesundheit herrühren oder Garantien betreffen.

Im Falle einer einfach fahrlässigen Verletzung einer wesentlichen Vertragspflicht haften wir allerdings nur für den nach Art des Vertragsschlusses vorhersehbaren, vertragstypischen, unmittelbaren Durchschnittsschaden.

Wir sind zu Teillieferungen und Teilleistungen nur berechtigt, wenn

- die Teillieferung oder Teilleistung für den Kunden im Rahmen des vertraglichen Bestimmungszwecks verwendbar ist,
  - die Lieferung der restlichen bestellten Waren bzw. die Erbringung der restlichen beauftragten Leistungen sichergestellt ist und
  - dem Kunden hierdurch kein erheblicher Mehraufwand oder zusätzliche Kosten entstehen (es sei denn, wir erklären uns zur Übernahme dieser Kosten bereit).
6. Kommt der Käufer in Annahmeverzug, so sind wir berechtigt, Ersatz des entstehenden Schadens und etwaiger Mehraufwendungen zu verlangen. Gleiches gilt, wenn der Käufer Mitwirkungspflichten schuldhaft verletzt.

## V. Erfüllungsort, Gefahrübergang, Versand, Verpackung

1. Die Lieferung erfolgt ab Lager in Öhringen, wo auch der Erfüllungsort für die Lieferung ist. Dies gilt auch für den Fall der Nacherfüllung. Auf Verlangen und Kosten des Käufers wird die Ware an einen anderen Bestimmungsort versandt (Versendungskauf).
2. Die Gefahr des zufälligen Untergangs und der zufälligen Verschlechterung der Ware geht spätestens mit der Übergabe auf den Käufer über. Beim Versendungskauf geht jedoch die Gefahr des zufälligen Untergangs und der zufälligen Verschlechterung der Ware sowie die Verzögerungsgefahr bereits mit Auslieferung der Ware an den Spediteur, den Frachtführer oder der sonst zur Ausführung der Versendung bestimmten Person oder Anstalt über. Der Übergabe steht es gleich, wenn der Käufer im Verzug der Annahme ist.
3. Wir werden uns bemühen, hinsichtlich Versandart und Versandweg Wünsche und Interessen des Käufers zu berücksichtigen; dadurch bedingte Mehrkosten - auch bei vereinbarter Frachtfreilieferung - gehen zu Lasten des Käufers.
4. Wir nehmen Transport- und alle sonstigen Verpackungen nach Maßgabe der Verpackungsverordnung nicht zurück; ausgenommen sind Paletten. Der Käufer hat für die Entsorgung der Verpackung, welche in sein Eigentum übergeht, auf eigene Kosten zu sorgen.
5. Wird der Versand auf Wunsch oder wegen Verschuldens des Käufers verzögert, so lagern wir die Waren auf Kosten und Gefahr des Käufers. In diesem Fall steht die Anzeige der Versandbereitschaft dem Versand gleich.
6. Auf Wunsch und Kosten des Käufers werden wir die Lieferung durch eine Transportversicherung absichern. Hierzu bedarf es einer ausdrücklichen Weisung des Käufers in Textform.

## VI. Gewährleistung / Haftungsbegrenzung / Ersatz vergeblicher Aufwendungen

1. Mängelansprüche des Käufers bestehen nur, wenn der Käufer seinen gesetzlich geschuldeten Untersuchungs- und Rügepflichten, insbesondere gemäß § 377 HGB, ordnungsgemäß nachgekommen ist. Unbeschadet der gesetzlichen Anforderungen an eine ordnungsgemäße Untersuchung hat der Käufer die gelieferte Ware nach Ablieferung bei ihm oder dem von ihm bestimmten Dritten sorgfältig und in zumutbarem Umfang - gegebenenfalls stichprobeweise - mindestens auf Maßhaltigkeit, Material, Gewicht und Oberflächenbeschaffenheit zu untersuchen. Dabei erkennbar werdende Mängel sind uns innerhalb einer Woche nach Eingang der Ware in Textform anzuzeigen. Geschieht dies nicht, gilt die Ware als genehmigt. Versteckte Mängel sind S + P unverzüglich in Textform nach ihrer Entdeckung mitzuteilen. Eine ordnungsgemäße Mängelrüge hat die Bereitschaft des Käufers erkennen zu lassen, den beanstandeten Liefergegenstand auf Verlangen von S + P frachtfrei zurückzusenden. Bei berechtigter Mängelrüge vergütet S + P die Kosten des günstigsten Versandweges; dies gilt nicht, soweit die Kosten sich erhöhen, weil der Liefergegenstand sich an einem anderen Ort als dem Ort des bestimmungsgemäßen Gebrauchs befindet. Versäumt der Käufer die ordnungsgemäße Untersuchung und/oder Mängelanzeige, ist unsere Haftung für den nicht bzw. nicht rechtzeitig oder nicht ordnungsgemäß angezeigten Mangel nach den gesetzlichen Vorschriften ausgeschlossen. Bei einer zum Einbau, zur Anbringung oder Installation bestimmten Ware gilt dies auch dann, wenn der Mangel infolge der Verletzung einer dieser Pflichten erst nach der entsprechenden Verarbeitung offenbar wurde; in diesem Fall bestehen insbesondere keine Ansprüche des Käufers auf Ersatz entsprechender Kosten (Aus- und Einbaukosten).
  2. Für die Rechte des Käufers bei Sach- und Rechtsmängeln (einschließlich Falsch- und Minderlieferung sowie unsachgemäßer Montage oder mangelhafter Montageanleitung) gelten die gesetzlichen Vorschriften, soweit nicht vorstehend oder nachfolgend ein anderes bestimmt ist.
  3. Grundlage unserer Mängelhaftung ist vor allem die über die Beschaffenheit und die vorausgesetzte Verwendung der Ware (einschließlich Zubehör und Anleitungen) getroffene Vereinbarung. Als Beschaffenheitsvereinbarung in diesem Sinne gelten alle Produktbeschreibungen und Herstellerangaben, die Gegenstand des einzelnen Vertrages sind oder von uns (insbesondere in Katalogen oder auf unserer Internet-Homepage) zum Zeitpunkt des Vertragsschlusses öffentlich bekannt gemacht waren. Soweit die Beschaffenheit nicht vereinbart wurde, ist nach der gesetzlichen Regelung zu beurteilen, ob ein Mangel vorliegt oder nicht (§ 434 Abs. 3 BGB). Öffentliche Äußerungen des Herstellers oder in seinem Auftrag insbesondere in der Werbung oder auf dem Etikett der Ware gehen dabei Äußerungen sonstiger Dritter vor.
  4. Unabhängig von den vorstehenden und nachstehenden Regelungen gelten die gesetzlichen Vorschriften in jedem Fall
    - bei vorsätzlichem Handeln unsererseits oder arglistigem Verschweigen eines Mangels;
    - bei Schäden aus der Verletzung des Lebens, des Körpers oder der Gesundheit;
    - bei Ansprüchen nach dem Produkthaftungsgesetz;
    - soweit von uns übernommene Garantien den abweichenden Regelungen entgegenstehen.
- In allen Fällen unberührt bleiben die gesetzlichen Sondervorschriften zum Aufwendungsersatz bei Endlieferung der neu hergestellten Ware an einen Verbraucher (Lieferantenregress gem. §§ 478, 445a, 445b bzw. §§ 445c, 327 Abs. 5, 327u BGB), sofern nicht, z.B. im Rahmen einer Qualitätssicherungsvereinbarung, ein gleichwertiger Ausgleich vereinbart wurde.

5. Im Übrigen gelten für die Rechte des Käufers bei Sach- und Rechtsmängeln folgende Besonderheiten:

a) Haftung auf Schadensersatz und Ersatz vergeblicher Aufwendungen  
Schadensersatzansprüche wegen Rechts- und Sachmängeln sind ausgeschlossen, soweit sie nicht - auf einem grob fahrlässigen Handeln unsererseits oder unserer Erfüllungsgehilfen oder - auf der schuldhaften Verletzung wesentlicher Vertragspflichten beruhen. Wesentlich sind diejenigen Vertragspflichten, die vertragswesentliche Rechtspositionen des Kunden schützen, die ihm der Vertrag nach seinem Inhalt und Zweck gerade zu gewähren hat; wesentlich sind ferner solche Vertragspflichten, deren Erfüllung die ordnungsgemäße Durchführung des Vertrages überhaupt erst ermöglicht und auf deren Einhaltung der Vertragspartner regelmäßig vertraut und auch vertrauen darf. Im Falle einer einfach fahrlässigen Verletzung einer wesentlichen Vertragspflicht haften wir nur für den nach Art des Vertragsschlusses vorhersehbaren, typischerweise eintretenden Schaden.

Ansprüche auf Ersatz vergeblicher Aufwendungen nach § 284 BGB sind dann und insoweit abbedungen, als nach dem zuvor Gesagten ein Anspruch auf Ersatz des Schadens statt der Leistung in wirksamer Weise freigezeichnet worden ist.

b) Nacherfüllung

- Ist die gelieferte Sache mangelhaft, können wir zunächst wählen, ob wir Nacherfüllung durch Beseitigung des Mangels (Nachbesserung) oder durch Lieferung einer mangelfreien Sache (Ersatzlieferung) leisten. Ist die von uns gewählte Art der Nacherfüllung im Einzelfall für den Käufer unzumutbar, kann er sie ablehnen. Unser Recht, die Nacherfüllung unter den gesetzlichen Voraussetzungen zu verweigern, bleibt unberührt.

- Würde die von S + P gelieferte Ware beim Käufer selbst bereits in eine andere Sache eingebaut oder an eine andere Sache angebracht, hat uns der Käufer, soweit dies für ihn zumutbar ist, zum Zwecke der Nacherfüllung Gelegenheit zu geben, die Ware selbst zu entfernen und die nachgebesserte oder nachgelieferte Ware selbst erneut einzubauen bzw. anzubringen und uns hierzu eine angemessene Frist zu bestimmen. Dies gilt unabhängig davon, ob wir ursprünglich zusätzlich zur Lieferung auch zum Einbau der Ware oder zu deren Montage verpflichtet waren; durch dieses Vorgehen wird der Einbau oder die Montage der gelieferten Ware auch nicht zum Teil der Nacherfüllung.  
- Hat der Käufer die durch S + P gelieferte Ware bereits weiterverkauft, hat der Käufer gegenüber S + P auch dann eine vorherige und angemessene Frist zur Nacherfüllung zu setzen, wenn der Käufer die Ware von seinem Abnehmer in Folge der Mangelhaftigkeit zurücknehmen musste oder der Abnehmer des Käufers den Kaufpreis gemindert hat.

- Unser Recht, die Nacherfüllung unter den gesetzlichen Voraussetzungen zu verweigern, bleibt unberührt.

c) Ersatz von Aufwendungen zur Nacherfüllung

- Der Käufer ist erst berechtigt, bei ihm selbst zum Zwecke der Nacherfüllung erforderlich werdende Aufwendungen, insbesondere zum Aus- und Wiedereinbau der Sache bzw. zum Entfernen und Wiederanbringen derselben, unter den weiteren gesetzlichen Voraussetzungen von S + P ersetzt zu verlangen, wenn die vom Käufer hierzu bestimmte angemessene Frist fruchtlos verstrichen ist.

- Musste die durch S + P gelieferte Sache im Falle der Weiterveräußerung durch den Käufer zum Zwecke der Nacherfüllung bei dessen direktem oder einem weiteren Abnehmer in der Lieferkette aus- und wiedereingebaut bzw. entfernt und wiederangebracht werden, ist S + P dem Käufer gegenüber nicht zum Ersatz der hierfür angefallenen Aufwendungen verpflichtet.

- Stellt sich heraus, dass das Mangelbeseitigungsverlangen des Käufers unberechtigt war, kann S + P von ihm die entstandenen Kosten (insbesondere Prüf-, Ein- und Ausbau- sowie Transportkosten) ersetzt verlangen, es sei denn, die fehlende Mangelhaftigkeit war für den Käufer nicht erkennbar. Dies vorstehend unter lit. b) und c) genannten Besonderheiten gelten nicht im Falle von Aufwendungsersatz bei Endlieferung neu hergestellter Ware an einen Verbraucher (Lieferantenregress gem. §§ 478, 445a, 445b bzw. §§ 445c, 327 Abs. 5, 327u BGB), sofern nicht, z.B. im Rahmen einer Qualitätssicherungsvereinbarung, ein gleichwertiger Ausgleich vereinbart wurde.

6. In den Fällen der Lieferung von neu hergestellter Ware durch S + P, die am Ende der Lieferkette in unverarbeitetem Zustand durch einen Unternehmer an einen Verbraucher verkauft werden, auch wenn letzterer sie weiterverarbeitet hat, gelten für die Rechte des Käufers weiter folgende Besonderheiten:

- Die Ansprüche des Käufers aus § 478 BGB sind ausgeschlossen, soweit es sich um einen Mangel aufgrund von Werbeaussagen oder sonstigen vertraglichen Vereinbarungen handelt, die nicht von S + P herrühren, oder wenn der Käufer, sein unmittelbarer oder ein weiterer Abnehmer in der Lieferkette gegenüber dem Endverbraucher eine besondere Garantie abgegeben hat.

- Diese Ansprüche sind ebenfalls ausgeschlossen, wenn der Käufer, sein unmittelbarer oder ein weiterer Abnehmer in der Lieferkette selbst nicht aufgrund der gesetzlichen Regelungen zur Ausübung der Gewährleistungsrechte gegenüber dem Endverbraucher verpflichtet war oder diese Rüge gegenüber einem ihm gestellten Anspruch nicht vorgenommen hat. Dies gilt auch, wenn der Käufer, sein unmittelbarer oder ein weiterer Abnehmer in der Lieferkette gegenüber dem Endverbraucher Gewährleistungen übernommen hat, die über das gesetzliche Maß hinausgehen.

- Die Ansprüche des Käufers aus § 478 BGB sind insgesamt ausgeschlossen, wenn der Käufer seinen gesetzlich geschuldeten Untersuchungs- und Rügepflichten nach näherer Maßgabe des Abschnitts VI Ziff. 1 nicht ordnungsgemäß nachgekommen ist.

## VII. Sonstige Haftung

Schadensersatzansprüche wegen Verletzung einer außervertraglichen Pflicht (Haftung aus Delikt) oder wegen Verschuldens bei oder im Vorfeld des Vertragsschlusses (culpa in contrahendo) sowie aus sonstigen Rechtsgründen, insbesondere der Verletzung allgemeiner Rücksichtnahmepflichten (§ 241 Abs. 2 BGB), der fehlerhaften oder unterlassenen Ausführung von vor oder nach Vertragsschluss erfolgten Vorschlägen oder Beratungen oder der Verletzung sonstiger Vertragspflichten (§ 280 Abs. 1 BGB), soweit es sich nicht bereits um Gewährleistungsansprüche handelt, sind ausgeschlossen, soweit sie nicht auf ein vorsätzliches, arglistiges oder grob fahrlässiges Handeln unsererseits oder unserer Erfüllungsgehilfen oder auf der schuldhaften Verletzung wesentlicher Vertragspflichten beruhen.

Der Haftungsausschluss gilt nicht für Schäden, welche aus der Verletzung des Lebens, des Körpers oder der Gesundheit herrühren oder Garantien sowie Ansprüche aus dem Produkthaftungsgesetz betreffen.

Im Falle einer einfach fahrlässigen Verletzung einer wesentlichen Vertragspflicht haften wir allerdings nur für den nach Art des Vertragsschlusses vorhersehbaren, typischerweise eintretenden Schaden.

## VIII. Verjährung

1. Abweichend von § 438 Abs. 1 Nr. 3 BGB beträgt die allgemeine Verjährungsfrist für Ansprüche aus Sach- und Rechtsmängeln einschließlich des Anspruchs auf Aufwendungsersatz in der Lieferkette nach § 445a Abs. 1, Abs. 3 BGB ein Jahr ab Ablieferung. Soweit eine Abnahme vereinbart ist, beginnt die Verjährung mit der Abnahme.

2. Handelt es sich bei der Ware jedoch um ein Bauwerk oder eine Sache, die entsprechend ihrer üblichen Verwendungsweise für ein Bauwerk verwendet worden ist und dessen Mangelhaftigkeit verursacht hat, beträgt die Verjährungsfrist gemäß der gesetzlichen Regelung fünf Jahre ab Ablieferung (§ 438 Abs. 1 Nr. 2 BGB). Unberührt bleiben auch weitere gesetzliche Sonderregelungen zur Verjährung (insbes. § 438 Abs. 1 Nr. 1, Abs. 3, §§ 444, 445b BGB).

3. Handelt es sich bei der Ware um solche Gegenstände, die für ein Bauwerk, aber auch für andere Dienst- und Werkleistungen verwendet werden können, verbleibt es bei der Verjährungsfrist gem. Ziff. 1, es sei denn, wenn der Einbau der Ware für das Bauwerk von wesentlicher Bedeutung war; dann gilt die Verjährungsfrist gem. Ziff. 2.

4. Abweichend von § 445b Abs. 2 S. 2 BGB endet im Falle der Weiterveräußerung der von S + P

gelieferten Ware durch den Käufer gegenüber S + P die Ablaufhemmung hinsichtlich der Verjährung von Mängelansprüchen des Käufers drei Jahre nach Ablieferung der Ware.

5. Die vorstehenden Verjährungsfristen des Kaufrechts gelten auch für vertragliche und außervertragliche Schadensersatzansprüche des Käufers, die auf einem Mangel der Ware beruhen, es sei denn die Anwendung der regelmäßigen gesetzlichen Verjährung (§§ 195, 199 BGB) würde im Einzelfall zu einer kürzeren Verjährung führen. Schadensersatzansprüche des Käufers aus Vorsatz, grober Fahrlässigkeit, der Verletzung von Leben, Körper oder Gesundheit sowie aus Garantien oder dem Produkthaftungsgesetz verjähren jedoch ausschließlich nach den gesetzlichen Verjährungsfristen. Die Verkürzung der Verjährungsfrist bzw. der Ablaufhemmung gilt auch dann nicht, wenn es sich um einen Fall der Lieferung von Waren durch S + P handelt, die am Ende der Lieferkette in unverarbeitetem Zustand durch einen Unternehmer an einen Verbraucher verkauft werden (Rückgriff des Unternehmers - §§ 478, 479 BGB).

## IX. Eigentumsvorbehalt

1. Die von uns gelieferte Ware bleibt bis zur Erfüllung sämtlicher bestehender oder künftig entstehender Forderungen, die uns aus irgendeinem Rechtsgrund aus der laufenden Geschäftsbeziehung und/oder dem konkreten Kaufvertrag gegenüber dem Käufer zustehen, unser Eigentum. Im Falle des vertragswidrigen Verhaltens des Käufers, z.B. Zahlungsverzug, haben wir nach vorheriger Setzung einer angemessenen Frist das Recht, die Vorbehaltsware zurückzunehmen. Nehmen wir die Vorbehaltsware zurück, stellt dies einen Rücktritt vom Vertrag dar. Pfänden wir die Vorbehaltsware, ist dies ein Rücktritt vom Vertrag. Wir sind berechtigt, die Vorbehaltsware nach der Rücknahme zu verwerten. Nach Abzug eines angemessenen Betrages für die Verwertungskosten, ist der Verwertungserlös mit den uns vom Käufer geschuldeten Beträgen zu verrechnen.

2. Der Käufer hat die Vorbehaltsware pfleglich zu behandeln und diese auf seine Kosten gegen Feuer-, Wasser- und Diebstahlschäden ausreichend zum Neuwert zu versichern. Wartungs- und Inspektionsarbeiten, die erforderlich werden, sind vom Käufer auf eigene Kosten rechtzeitig durchzuführen. Der Käufer ist außerdem verpflichtet, auf Verlangen von S + P, uns jederzeit über den Zustand der Ware Auskunft zu geben und den Aufbewahrungsort der Ware mitzuteilen.

3. Der Käufer ist berechtigt, die Vorbehaltsware im ordnungsgemäßen Geschäftsgang zu veräußern und/oder zu verwenden, solange er nicht in Zahlungsverzug ist. Verpfändungen oder Sicherungsübereignungen sind unzulässig. Die aus dem Weiterverkauf oder einem sonstigen Rechtsgrund (Versicherung, unerlaubte Handlung) bezüglich der Vorbehaltsware entstehenden Forderungen (einschließlich sämtlicher Saldoforderungen aus Kontokorrent) tritt der Käufer bereits jetzt sicherungshalber in vollem Umfang an uns ab; wir nehmen die Abtretung hiermit an. Wir ermächtigen den Käufer widerruflich, die an uns abgetretenen Forderungen für dessen Rechnung im eigenen Namen einzuziehen. Die Einzugsermächtigung kann jederzeit widerrufen werden, wenn der Käufer seinen Zahlungsverpflichtungen nicht ordnungsgemäß nachkommt. Zur Abtretung dieser Forderung ist der Käufer auch nicht zum Zwecke des Forderungseinzugs im Wege des Factoring befugt, es sei denn, es wird gleichzeitig die Verpflichtung des Factors begründet, die Gegenleistung in Höhe der Forderungen solange unmittelbar an uns zu bewirken, als noch Forderungen von uns gegen den Käufer bestehen. Der Käufer ist außerdem verpflichtet, uns von einer Pfändung oder einer anderen Beeinträchtigung durch Dritte unverzüglich zu benachrichtigen.

4. Eine Verarbeitung oder Umbildung der Vorbehaltsware durch den Käufer wird in jedem Fall für uns vorgenommen. Sofern die Vorbehaltsware mit anderen, uns nicht gehörenden Sachen verarbeitet wird, erwerben wir das Miteigentum an der neuen Sache im Verhältnis des Wertes der Vorbehaltsware (Rechnungsbetrag inklusive der Mehrwertsteuer) zu den anderen verarbeiteten Sachen im Zeitpunkt der Verarbeitung. Im Falle der untrennbaren Vermischung der Vorbehaltsware mit anderen, uns nicht gehörenden Sachen erwerben wir Miteigentum an der neuen Sache im Verhältnis des Wertes der Vorbehaltsware (Rechnungsbetrag inklusive der Mehrwertsteuer) zu den anderen vermischten Sachen im Zeitpunkt der Vermischung. Ist die Sache des Käufers in Folge der Vermischung als Hauptsache anzusehen, sind der Käufer und wir uns einig, dass der Käufer uns anteilmäßig Miteigentum an dieser Sache überträgt; die Übertragung nehmen wir hiermit an. Unser so entstandenes Allein- oder Miteigentum an einer Sache verwahrt der Käufer für uns. Für die durch Verarbeitung oder Umbildung entstehende neue Sache gilt das Gleiche wie für die Vorbehaltsware, allerdings mit der Einschränkung, dass der Käufer Forderungen Dritter lediglich in der Höhe an uns abtrifft, als wir Miteigentum entsprechend dem zuvor Gesagten erworben haben.

5. Bei Zugriffen Dritter auf die Vorbehaltsware, insbesondere Pfändungen, wird der Käufer auf unser Eigentum hinweisen und uns unverzüglich benachrichtigen, damit wir unsere Eigentumsrechte durchsetzen können. Soweit der Dritte nicht in der Lage ist, uns die in diesem Zusammenhang entstehenden gerichtlichen oder außergerichtlichen Kosten zu erstatten, haftet hierfür der Käufer.

6. Wir sind verpflichtet, die uns zustehenden Sicherheiten insoweit freizugeben, als der realisierbare Wert unserer Sicherheiten die zu sichernden Forderungen um mehr als 10 % übersteigt, dabei obliegt uns die Auswahl der freizugebenden Sicherheiten.

## X. Gerichtsstand, anzuwendendes Recht

1. Ist der Käufer Kaufmann i.S.d. Handelsgesetzbuchs, juristische Person des öffentlichen Rechts oder ein öffentlich-rechtliches Sondervermögen, ist ausschließlicher – auch internationaler – Gerichtsstand für alle sich aus dem Vertragsverhältnis unmittelbar oder mittelbar ergebenden Streitigkeiten Heilbronn, Deutschland. Entsprechendes gilt, wenn der Käufer Unternehmer i.S.v. § 14 BGB ist. Wir sind jedoch in allen Fällen auch berechtigt, Klage am Erfüllungsort der Lieferverpflichtung des Käufers zu erheben. Vorrangige gesetzliche Vorschriften, insbesondere zu ausschließlichen Zuständigkeiten, bleiben unberührt. 2. Das Rechtsverhältnis zwischen uns und unseren Kunden oder zwischen uns und Dritten regelt sich ausschließlich nach dem in der Bundesrepublik Deutschland geltenden Recht unter Ausschluss internationalen Einheitsrechts, insbesondere des UN-Kaufrechts.

## XI. Sonstiges

1. Sollten diese Bestimmungen teilweise rechtsunwirksam oder lückenhaft sein oder werden oder durch eine Sondervereinbarung ausgeschlossen sein, so wird hierdurch die Gültigkeit der übrigen Bestimmungen nicht berührt.

2. Wir weisen darauf hin, dass wir Daten unserer Kunden im Rahmen unserer gegenseitigen Geschäftsbeziehungen nach den geltenden datenschutzrechtlichen Bestimmungen, insbesondere der Europäischen Datenschutz-Grundverordnung und dem Bundesdatenschutzgesetz speichern.

Schäfer + Peters GmbH

# General Terms of Sale and Delivery of Schäfer + Peters GmbH (hereinafter referred to as “S + P”) Version 10/2022

## I. Scope of Validity

1. The terms of sale given hereinafter apply to all contracts concluded between the Purchaser and S + P concerning the delivery of goods, provided that the Purchaser is a company, legal entity under public law or special fund under public law. Contracts are executed exclusively on the basis of the following conditions. The quotation, the quotation acceptance and the order confirmation, as well as the sale of any product, are subject to these conditions. We shall not recognise any contradictory or deviating conditions of purchase, unless we have expressly agreed to apply these conditions. This consent requirement shall always apply, particularly if we carry out the Purchaser's order without qualification and in full knowledge of these contradictory or deviating conditions of the Purchaser.
2. In the contracts, all agreements that have been made between the Purchaser and S + P about the execution of the purchasing contracts up to the time of the respective conclusion of the contract are documented in writing. The effectiveness of individual agreements made retroactively in individual cases remains unaffected.
3. If S + P and the Purchaser have arranged a framework agreement, these General Terms of Sale shall apply both to this framework agreement and to the individual delivery or purchase order.
4. The General Terms of Sale shall also apply to all future business relationships, even if these terms are never agreed on expressly.

## II. Offer and Contract Conclusion

1. We can accept an order from the Purchaser which is to be qualified as a legally binding offer for the conclusion of a purchasing contract within two weeks by sending an order confirmation or by rendering the deliveries or services ordered without qualification, with the choice being ours.
2. Our quotations are non-binding, unless we have expressly designated them as binding. Information about our goods (particularly technical data, dimensions, performance and consumption data, as well as the descriptions in the respective product information or advertising materials, etc.) is only approximate and roughly representative, provided that usability for the contractually intended purpose does not require an exact match; this information does not guarantee the condition, unless this guarantee is made expressly and in writing.
3. We retain our property right, copyright and other protective rights on all figures, calculations, drawings and other documents. The Purchaser may only pass on these items, regardless of whether we have marked them as confidential, to third parties in text form as such or in terms of content, disclose them, use them themselves or have them used by third parties or reproduce them with our consent.
4. Information about current warehouse inventory is always non-binding. If inventory is communicated to the customer, this is considered inventory that is specifically reserved for customer or volume groups and does not need to be identical to the actual inventory.

## III. Terms of Payment

1. Our prices apply to the scope of service and delivery indicated in the order confirmations. Additional or special services are billed separately. Prices shall apply ex works in Öhringen, plus packaging, duties, insurance and, in individual cases, additional taxes and duties, if not otherwise specified. The statutory value added tax is not included in our prices. We list this in the invoice separately in the statutory amount on the date the invoice is issued.
2. Unless otherwise agreed, invoices shall be due and payable without deduction within 30 days from the date of invoicing and delivery. We grant a discount of 2% for payments made within 10 days of the date of invoice, unless the Purchaser is in default of payment for other payment obligations towards us. Payment is only considered to have occurred once the funds are available to us. In the case of cheque payments, payment is only considered to have occurred once the cheque has cleared.
3. If the Purchaser does not pay within the defined period, the Purchaser shall be in default of payment, without a new payment request needing to be made. In the case of late payment, interest is to be paid on the purchase price at the legally applicable late payment interest rate for business owners. Further claims shall remain unaffected. If the Purchaser does not render payment upon further request, we are entitled to make all existing obligations of the Purchaser due and payable, in particular also deferred or instalment payments, and to deny any further deliveries.
4. The Purchaser shall be authorised to offset and/or withhold payment only if the counter-claims have been determined as legally valid, have been recognised by us, are indisputable or if the counter-claims arise from the same specific contractual relationship as the principal claim and are in a mutual relationship with this claim.
5. If S + P has granted instalment payments for the Purchaser, the remaining amount shall be due and payable in full if the Purchaser is in default of payment of an instalment by more than 8 days.
6. Price changes are permitted if more than four months have passed between the contract conclusion and the agreed delivery date and if the price change can be traced back to a recent cost increase for which we are not liable. A cost increase has occurred if wages, material costs, transport costs ancillary transport costs or sales costs increase before delivery. The same applies if duties increase or a duty is introduced, or cost changes result due to price increases of upstream suppliers or due to exchange rate fluctuations. In these cases, S + P is authorised to increase the price appropriately in accordance with the cost increases.

## IV. Delivery and Service Period, Liability in Case of Late Delivery

1. Delivery dates or deadlines that are not agreed upon or promised by us expressly as binding are exclusively non-binding specifications. They shall only be considered approximations and describe a likely delivery date. Agreements or promises about a binding delivery date deviating from this must be made expressly and in writing. The delivery period only begins when the Purchaser has properly and completely performed those cooperation activities that are obligatory on its part.
2. If we do not receive deliveries or services from our sub-suppliers or subcontractors, or do not receive correct or timely deliveries or services for reasons for which we are not responsible despite proper coverage, or if an event of force majeure occurs, we shall inform our customer in writing in a timely manner. In this case, we are authorised to extend the delivery or service period by the duration of the temporary hindrance or, in the case of a significant hindrance whose duration is not temporary, to withdraw from the part of the contract that has not yet been fulfilled, entirely or in part, if we have performed the above obligation of notification and have not assumed the procurement risk or production risk. Force majeure includes any other unforeseeable event upon contract conclusion, such as legal strikes or lockouts, government interventions, energy and resource shortages, transport bottlenecks or operational disturbances through no fault of our own, such as those due to fire, water and machine damage, unexpectedly occurring pandemics or epidemics, acts of war and war-like acts, economic sanctions and all other hindrances for which we objectively cannot be held responsible. If the delivery or service is delayed by more than one month as a result of one of the cases named above in Clauses 1 and 3, both we and the customer regardless of the deadline requirement for the customer and excluding any claims for damages – are authorised to withdraw from the contract with regard to the volume affected by the delivery disturbances. The customer is authorised to withdraw from the entire contract if a partial delivery is unacceptable for the customer.
3. In any case, we shall enter into default of delivery only after an appropriate grace period set by the customer has passed, unless time is of the essence for the transaction as defined by § 286 para. 2 No. 4 of the German Civil Code (BGB) or § 376 of the German Commercial Code (HGB).
4. Our legal rights, particularly in the case of an exclusion of the duty to perform (e.g. due to impossibility or unreasonableness of performance and/or supplementary performance), remain unaffected. Claims for damages due to delayed delivery are excluded, provided that they are not based on any intentional or grossly negligent actions on our part or on the part of our subcontractors, or based on the culpable violation of essential contractual duties. Essential contractual duties are any that protect the essential legal positions of the customer, the guarantee of which is the very essence and

purpose of the contract; these also include those contractual duties whose performance enables the proper completion of the contract in the first place and those whose observance the contract partner frequently trusts and may reasonably trust.

The exclusion of liability does not apply to damages caused by injury to life, limb and health or damages affecting warranties.

In the case of a simple negligent violation of an essential contractual duty, however, we shall only accept liability for typical, immediate, average damage foreseeable at the time that the contract was concluded.

5. We are only authorised to perform partial deliveries and partial services if:

- the partial delivery or partial service is usable for the customer as part of the intended purpose of the contract,
- the delivery of the remaining ordered goods or the rendering of the remaining commissioned services is ensured, and
- this does not cause any significant added outlay or extra costs for the customer (unless we have agreed to accept these costs).

6. If the Purchaser is in default of acceptance, we are then entitled to demand compensation for accrued damages and any extra expenses. The same applies if the Purchaser culpably violates its cooperation duties.

## V. Place of Fulfilment, Transfer of Risk, Shipping, Packaging

1. Delivery shall be ex warehouse in Öhringen, which is also the place of performance for the delivery. This shall also apply in the event of subsequent performance. At the request and expense of the Purchaser, the goods will be shipped to another destination (sale by delivery to a place other than the place of performance).

2. The risk of accidental loss and accidental deterioration of the goods shall transfer to the Purchaser upon handover at the latest. In the case of sales shipment, however, the risk of accidental destruction and accidental deterioration of the goods, as well as the risk of delay, passes to the shipper, freight carrier or other person or institution assigned to complete the shipment upon handover of the goods for shipment. Handover is still considered to have taken place if the Purchaser is in default of acceptance.

3. With regard to the shipment method and shipping route, we shall try to take into consideration the wishes and interests of the Purchaser; added costs caused by this – even in the case of agreed free delivery – shall be borne by the Purchaser.

4. We do not take back transport packaging or any other packaging in accordance with the packaging ordinance; this excludes pallets. The Purchaser shall take care of disposal of the packaging, which becomes its property, at the Purchaser's own expense.

5. If the shipping is delayed on the request of or due to fault of the Purchaser, we shall store the goods at the Purchaser's risk and expense. In this case, the notice of readiness to ship shall be deemed equivalent to shipment.

6. On request and at the expense of the Purchaser, we shall insure the delivery using transport insurance. This requires an instruction from the Purchaser given expressly and in writing.

## VI. Warranty/Limitation of Liability/Compensation for Wasted Expenditures

1. There shall only be claims for defects from the Purchaser if the Purchaser has properly fulfilled its legally required examination and notification duties, particularly in accordance with § 377 HGB. Regardless of the legal requirements for proper examination, the Purchaser shall at least examine the supplied goods after delivery at its location or that of a third party designated by the Purchaser carefully and in a reasonable scope – if applicable, through random checks – at least for dimensional accuracy, material, weight and surface condition. Defects that are revealed in this way shall be indicated to us in writing within one week of receipt of goods. If this does not occur, the goods shall be considered accepted. Hidden defects shall be communicated to S + P immediately after their discovery in writing. A proper notification of a defect shall indicate the willingness of the Purchaser to send back the rejected delivered goods on the request of S + P with freight prepaid. In the case of a justified notification of a defect, S + P shall compensate the Purchaser for the cost of the most economical shipping route; this shall not apply if costs increase because the delivered goods are located somewhere other than the place of intended use. If the Purchaser fails to carry out a proper inspection and/or to give notice of a defect, our liability for the defect which was not notified or not notified in time or not notified properly shall be excluded in accordance with the statutory provisions. In the case of goods intended for installation or mounting, this shall also apply if the defect only became apparent after the corresponding processing as a result of the breach of one of these obligations; in this case, the Purchaser shall, in particular, have no claims for reimbursement of the corresponding costs (dismantling and installation costs).

2. The legal regulations apply to the rights of Purchaser in the case of quality defects and defects of title (including incorrect and under delivery as well as improper assembly or defective assembly instructions), if not otherwise specified in preceding or following provisions.

3. The basis of our liability for defects is above all the agreement reached on the quality and the presupposed use of the goods (including any accessories and instructions). All product descriptions and manufacturer's specifications which are the subject of the individual contract or which were publicly announced by us (in particular in catalogues or on our Internet homepage) at the time of the conclusion of the contract shall be deemed to be an agreement on quality in this sense. Insofar as the quality was not agreed, it shall be assessed in accordance with the statutory regulation whether a defect exists or not (§ 434 para. 3 BGB (German Civil Code)). Public statements made by the manufacturer or on its behalf, in particular in advertising or on the label of the goods, take precedence over statements made by other third parties.

4. Independent of the preceding and following provisions, the legal regulations shall apply in the following cases:

- intentional actions on our part;
- damage due to injury to life, limb and health;
- claims in accordance with product liability law;
- if warranties taken over by us are excluded by deviating provisions.

In all cases, the special statutory provisions on the reimbursement of expenses in the case of final delivery of the newly manufactured goods to a consumer (supplier's recourse pursuant to §§ 478, 445a, 445b or §§ 445c, 327 para. 5, 327u BGB (German Civil Code)) shall remain unaffected, unless equivalent compensation has been agreed, e.g. within the scope of a quality assurance agreement.

5. Otherwise, the following aspects apply to the rights of the Purchaser in the case of quality defects and defects of title:

a) Liability for compensation for damages and compensation for wasted expenditures  
Claims for damages due to defects of title and quality defects are excluded, provided that they are not

- based on grossly negligent actions on our part or on the part of our subcontractors, or  
- based on the culpable violation of essential contractual duties. Essential contractual duties are any that protect the essential legal positions of the customer, the guarantee of which is the very essence and purpose of the contract; these also include those contractual duties, the performance of which enables the proper completion of the contract in the first place and on the observance of which the contracting partner frequently trusts and may reasonably trust.

In the event of a simple negligent breach of an essential contractual obligation, we shall only be liable for the typically foreseeable damage according to the type of contract conclusion.

Claims for compensation for wasted expenditures in accordance with § 284 BGB (German Civil Code) shall be waived if and insofar as, as stated previously, a claim for compensation for damages in place of performance has been effectively disclaimed.

#### b) Supplementary performance

- If the delivered item is defective, we can initially choose whether we shall provide subsequent performance by remedying the defect (rectification) or by delivering an item free of defects (replacement delivery). If the type of subsequent performance chosen by us is unreasonable for the Purchaser in the individual case, he may reject it. Our right to refuse subsequent performance under the statutory preconditions remains unaffected.

- If the Purchaser has already installed the goods delivered by S + P into another object or attached them to another object at its location, the Purchaser must offer us the opportunity to remove the goods ourselves and reinstall or reattach improved or additional goods ourselves, provided that this is reasonable for the Purchaser, for the purposes of supplementary performance, and to define an appropriate period for this. This shall apply regardless of whether we were originally required to install or assemble goods in addition to their delivery; using this approach, the installation or assembly of delivered goods does not become part of supplementary performance.

- If the Purchaser has already resold the goods delivered by S + P, the Purchaser shall set a prior and appropriate period for S + P for supplementary performance if the Purchaser has to take back the goods from its customer as a result of the defect or if the Purchaser's customer has reduced the purchase price.

- Our right to refuse supplementary performance in accordance with the legal requirements remains unaffected.

#### c) Compensation for expenses for supplementary performance

- The Purchaser is only entitled to demand compensation from S + P for expenses incurred by it for the purpose of subsequent performance, in particular for the removal and reinstallation of the item or for the removal and reinstallation of the same, under the further statutory conditions, if the reasonable period of time set by the Purchaser for this purpose has elapsed without success.

- If, in the case of resale by the Purchaser, the object delivered by S + P needed to be removed and reinstalled or removed and reattached at the location of a direct customer of the Purchaser or a different customer in the supply chain for the purposes of supplementary performance, S + P is not required to compensate the Purchaser for the expenses that arise from this.

- If it is revealed that the request for rectification from the Purchaser is unjustified, S + P can demand compensation from the Purchaser for the costs arising (particularly testing, installation, removal and transport costs), unless the lack of defect was not able to be determined by the Purchaser.

The special aspects mentioned above under items b) and c) do not apply in the case of reimbursement of expenses in the case of final delivery of newly manufactured goods to a consumer (supplier recourse according to §§ 478, 445a, 445b or §§ 445c, 327 para. 5, 327u BGB (German Civil Code)), unless equivalent compensation has been agreed, e.g. within the framework of a quality assurance agreement.

6. In case of delivery of newly produced goods by S + P that are sold at the end of the supply chain in unprocessed form by a business owner to a consumer, even if the latter has further processed it, the following additional aspects apply to the rights of the Purchaser:

- Claims of the Purchaser based on § 478 BGB are excluded, provided that they involve a defect based on advertising statements or other contractual agreements not originating from S + P, or if the Purchaser, its immediate customer or another customer in the supply chain has provided a special guarantee to the end user.

- Claims are also excluded if the Purchaser itself, its immediate customer or another customer in the supply chain was not required to exercise warranty rights toward the end user in accordance with legal regulations or if the Purchaser has not objected to a claim asserted against it. This also applies if the Purchaser, its immediate customer or another customer in the supply chain has taken over warranties vis-a-vis the end user that exceed the legal requirements.

- The claims of the Purchaser based on § 478 BGB (German Civil Code) are excluded as a whole if the Purchaser has not properly fulfilled its legally required examination and notification duties in accordance with the detailed specifications of Section VI No. 1.

#### VII. Other Liability

Claims for damages due to a violation of a non-contractual duty (liability based on tort) or due to fault during or before the conclusion of the contract (culpa in contrahendo) as well as any other legal basis, particularly the violation of general duties arising from an obligation (§ 241 para. 2 BGB (German Civil Code)) or other contractual duties (§ 280 para. 1 BGB), provided that this does not involve warranty claims, are excluded, provided that they are not based on intentional, fraudulent or grossly negligent actions on our part or on the part of our subcontractors or based on culpable violation of essential contractual duties.

The exclusion of liability does not apply to damages caused by injury to life, limb and health or damages affecting warranties and claims in accordance with product liability law.

In the case of a simple negligent violation of an essential contractual duty, however, we shall only accept liability for typical, immediate, average damage foreseeable at the time that the contract was concluded.

#### VIII. Limitation

1. Deviating from § 438 para. 1 No. 3 BGB (German Civil Code), the general limitation period for claims due to quality defects and defects of title, including the claim for reimbursement for expenses in the supply chain in accordance with § 445a para. 1, para. 3 BGB, is one year from delivery. If an acceptance has been agreed, the limitation begins upon acceptance.

2. However, if the goods constitute a building or an object that has been used as a building in the typical manner and has resulted in its defectiveness (building material), the limitation period is 5 years from delivery in accordance with the legal regulation (§ 438 para. 1 No. 2 BGB). Other legal special provisions on limitation remain unaffected (particularly § 438 para. 1 No. 1, para. 3, §§ 444, 445b BGB).

3. If the goods are items that can be used for a building, but also for other services and works, the limitation period pursuant to Clause 1 shall apply, unless the installation of the goods was of essential importance for the building. In that case, the limitation period pursuant to Clause 2 shall apply.

4. Deviating from § 445b Par. 2 S. 2 BGB, in the case of resale of the goods delivered by S + P by the Purchaser, the suspension of expiration regarding the limitation of defect claims from the Purchaser toward S + P ends three years after delivery of the goods.

5. The present limitation periods from the sale of goods law shall also apply to contractual and non-contractual claims for damages from the Purchaser based on a defect of the goods, unless the application of the regular legal limitation (§§ 195, 199 BGB) would lead to a shorter limitation in this individual case. However, claims for damages from the Purchaser due to wilful intent, gross negligence, injury to life, limb and health as well as warranties or product liability law expire by limitation only after the legal limitation periods. The shortening of the limitation period or the suspension of expiration shall also not apply if the matter involves the delivery of goods by S + P that are sold at the end of the supply chain in an unprocessed state by a business owner to a consumer (Recourse of the entrepreneur – §§ 478, 479 BGB).

#### IX. Retention of Title

1. The goods delivered by us shall remain our property up to the fulfilment of all existing claims or claims arising in future owed to us on any legal basis from the ongoing business relationship and/or specific purchasing contract with the Purchaser. In the case of the Purchaser behaviour that is contrary to the contract (e.g. payment default), we have the right to take back the reserved goods after first setting an appropriate period. If we take back the reserved goods, this represents a withdrawal from the contract. If we seize the reserved goods, this is a withdrawal from the contract. We

are authorised to utilize the reserved goods after taking them back. After withdrawing an appropriate amount for the utilisation costs, the proceeds of utilisation shall offset the amounts owed to us by the Purchaser.

2. The Purchaser shall treat the reserved goods with care and insure them against damage due to fire, water and theft sufficiently at original value at its own expense. The maintenance and inspection work that is required shall be performed by the Purchaser at its own expense in a timely manner. Furthermore, upon request by S + P, the Purchaser shall at any time notify us of the state of the goods and communicate the storage place of the goods.

3. The Purchaser is authorised to dispose of or use the reserved goods in the normal course of business, provided that the Purchaser is not in default of payment. Pledges or assignments as security are not permitted. The Purchaser shall assign claims arising from resale or another legal basis (insurance, tort) regarding the reserved goods (including all current account balance claims) to us in full scope as security; this statement constitutes our acceptance of the assignment. We revocably authorise Purchaser to collect claims assigned to us for Purchaser's account and in its own name. This collection authorisation can be revoked at any time if Purchaser does not properly fulfil its payment obligations. Purchaser shall also not be authorised to assign this claim for the purposes of debt collection by way of factoring, unless the obligation of the factor is simultaneously established to effect the consideration in the amount of the debts directly to us for as long as we still have claims against the Purchaser. The Purchaser shall furthermore obligated notify us immediately of any seizure or other interference by a third party.

4. Any transformation of the reserved goods by the Purchaser is always carried out on our behalf. If the reserved goods are processed with other items which do not belong to us, we shall acquire co-ownership of the new item in proportion to the value of the reserved goods (total invoice amount including value-added tax) to the other processed items at the time of the processing. In the case of inseparable combination of the reserved goods with other items that do not belong to us, we shall acquire co-ownership of the new item in proportion to the value of the reserved goods (total invoice amount including value-added tax) to the other combined items at the time of the combination. If the Purchaser's item is to be considered the main item as a result of combination, we and the Purchaser agree that the Purchaser shall transfer co-ownership of this item to us on a proportional basis; this statement constitutes our acceptance of this transfer. Our sole or co-ownership of an item arising from this shall be kept for us by the Purchaser. The same applies to the new item created through processing or transformation as to the reserved goods, but with the limitation that the Purchaser shall only assign claims of third parties to us in the amount that we have acquired through co-ownership according to the previous statement.

5. In case of access of third parties to the reserved goods, particularly seizures, the Purchaser shall indicate our property to the third parties and immediately notify us so that we may assert our property rights. If the third party is not able to reimburse us for the legal or out-of-court costs arising in this context, the Purchaser shall be liable for this.

6. We shall release the securities due to us insofar as the realisable value of our securities exceeds the secured claims by more than 10%, in which process we are at liberty to select the securities to be released.

#### X. Place of Fulfilment, Jurisdiction, Applicable Law

1. If the Purchaser is a merchant within the meaning of the German Commercial Code, a legal entity under public law or a special fund under public law, the exclusive – including international – place of jurisdiction for all disputes arising directly or indirectly from the contractual relationship shall be Heilbronn, Germany. The same shall apply if the buyer is an entrepreneur within the meaning of § 14 BGB (German Civil Code). However, we are also entitled in all cases to bring an action at the place of performance of the delivery obligation in accordance with these general terms of sale and delivery or a prior individual agreement or at the general place of jurisdiction of the buyer. Priority statutory provisions, in particular regarding exclusive jurisdiction, shall remain unaffected.

2. The legal relationship between us and our customers or between us and third parties shall be governed exclusively by applicable law in the Federal Republic of Germany, excluding international uniform law, particularly the UN Convention on Contracts for the International Sale of Goods.

#### XI. Other

1. If these provisions are or become partially void or incomplete or are excluded by a special agreement, the validity of the remaining provisions shall not be affected by this.

2. We would like to note that we store data of our customers as part of our mutual business relationships in accordance with applicable data protection regulations, particularly the European General Data Protection Regulation and the German Data Protection Act.

Schäfer + Peters GmbH



**Schäfer + Peters GmbH**

Zeilbaumweg 32  
DE-74613 Öhringen

Tel. +49 (0) 7941 6094-0  
info@schaefer-peters.com  
www.schaefer-peters.com

